

From: [Gell, Chris](#)
To: [ZAPARI Services Nathan Ross](#); [Davis, Matt](#)
Cc: [Varlow, Trent](#)
Subject: Kennedy St Kingston project presentation

Hi Nathan

Can we move this to 1.30 in case Trent is able to make it.

We have meetings before & after this time.

Thanks

Chris

-- Do not delete or change any of the following text. --

When it's time, join your Webex meeting here.

Join meeting <<https://actgov.webex.com/actgov/j.php?MTID=me8aed11a285b806a0765361503600246>>

More ways to join:

Join from the meeting link

<https://actgov.webex.com/actgov/j.php?MTID=me8aed11a285b806a0765361503600246> <<https://actgov.webex.com/actgov/j.php?MTID=me8aed11a285b806a0765361503600246>>

Join by meeting number

Meeting number (access code): 2658 241 0187

Meeting password: 3PsGSJien85

Tap to join from a mobile device (attendees only)

+61-2-9338-2221,,26582410187## <tel:%2B61-2-9338-2221,,*01*26582410187%23%23*01*> Australia Toll
+61-2-9053-7190,,26582410187## <tel:%2B61-2-9053-7190,,*01*26582410187%23%23*01*> Australia Toll 2

Join by phone

+61-2-9338-2221 Australia Toll
+61-2-9053-7190 Australia Toll 2

Global call-in numbers <<https://actgov.webex.com/actgov/globalcallin.php?MTID=m30187ba419b2745e31ea80a403c163ef>> | Toll-free calling restrictions <<https://cisco.com/go/tollfree-restrictions>>

Join from a video system or application

Dial [26582410187@actgov.webex.com](https://actgov.webex.com) <[sip:26582410187@actgov.webex.com](https://actgov.webex.com)>
You can also dial 210.4.202.4 and enter your meeting number.

If you are a host, click here <<https://actgov.webex.com/webappng/sites/actgov/meeting/info/1129b0dde02a4424af09eed0f35bcf63>> and login site to view host information.

Need help? Go to <https://help.webex.com> <<https://help.webex.com>>

From: Sch [redacted] | ZAPARI
To: Varlow, Trent; Nathan Ross | ZAPARI; Gell, Chris; Davis, Matt
Cc: Ronan Moss; "Bradley Yates"
Subject: RE: Kennedy St
Date: Friday, 2 June 2023 10:47:04 AM
Attachments: [image003.png](#)
[image004.png](#)
[image808cfc.PNG](#)
[imagef0a795.PNG](#)
[KennedySt_EPSDD Presentation_230531.pdf](#)

Some people who received this message don't often get email from [Sch 2.2\(a\)\(ii\)](#)@zapariserivces.com.au. [Learn why this is important](#)

Caution: This email originated from outside of the ACT Government. Do not click links or open attachments unless you recognise the sender and know the content is safe. [Learn why this is important](#)

Hi Trent,

Please see attached presentation from Wednesday.

Cheers,

Hamish Wise
Development Manager

10, 33 Bougainville Street | Manuka | ACT | 2603
PO Box 3120 Manuka ACT 2603
02 6285 7500 | [Sch 2.2\(a\)\(ii\)](#)
[Sch 2.2\(a\)\(ii\)](#)@zapariserivces.com.au | [zapari.com.au](#)

Zapari



The Shard



From: Varlow, Trent [mailto:Trent.Varlow@act.gov.au]
Sent: Thursday, 1 June 2023 2:23 PM
To: Nathan Ross | ZAPARI [Sch 2.2\(a\)\(ii\)](#)@zapariserivces.com.au>; Gell, Chris <Chris.Gell@act.gov.au>; Davis, Matt <Matt.Davis@act.gov.au>
Cc: Ronan Moss [Sch 2.2\(a\)\(ii\)](#)@cox.com.au>; 'Bradley Yates' [Sch 2.2\(a\)\(ii\)](#)@purdon.com.au>; Hamish Wise | ZAPARI [Sch 2.2\(a\)\(ii\)](#)@zapariserivces.com.au>
Subject: RE: Kennedy St

OFFICIAL

Hi Nathan,

Thanks for taking us through the proposal.

Happy to meet after you go over everything with KBRG again. If you could email across the presentation it would be appreciated.

Kind regards,

Trent Varlow
Director – Development Assessment
Statutory Planning
Environment Planning and Sustainable Development - ACT Government

From: Nathan Ross | ZAPARI [Sch.2.2\(a\)\(ii\)@zapariservices.com.au](mailto:Sch.2.2(a)(ii)@zapariservices.com.au)
Sent: Thursday, 1 June 2023 1:57 PM
To: Gell, Chris <Chris.Gell@act.gov.au>; Davis, Matt <Matt.Davis@act.gov.au>; Varlow, Trent <Trent.Varlow@act.gov.au>
Cc: Ronan Moss [Sch.2.2\(a\)\(ii\)@cox.com.au](mailto:Sch.2.2(a)(ii)@cox.com.au); 'Bradley Yates' [Sch.2.2\(a\)\(ii\)@purdon.com.au](mailto:Sch.2.2(a)(ii)@purdon.com.au); Hamish Wise | ZAPAR [Sch.2.2\(a\)\(ii\)@zapariservices.com.au](mailto:Sch.2.2(a)(ii)@zapariservices.com.au)
Subject: Kennedy St

Caution: This email originated from outside of the ACT Government. Do not click links or open attachments unless you recognise the sender and know the content is safe. [Learn why this is important](#)

Gents,

Thank you again for your time yesterday to discuss this project.

The team is updating everything over the next week or so to get back in front of the community group one last time before we lodge the DA.

We would appreciate if we could have a follow up presentation after we meet with the community. This will allow us to highlight any final changes in response to their comments. Once we secure a time with the KBRG we will let you know.

Please let me know if you weren't able to retain the presentation on your computer and we can email a copy.

Talk soon,

Cheers,

Nathan Ross

General Manager Developments

10, 33 Bougainville Street | Manuka | ACT | 2603
PO Box 3120 | Manuka | ACT | 2603
02 6285 7500 | [Sch.2.2\(a\)\(ii\)@zapariservices.com.au](mailto:Sch.2.2(a)(ii)@zapariservices.com.au) | zapari.com.au



This email, and any attachments, may be confidential and also privileged. If you are not the intended recipient, please notify the sender and delete all copies of this transmission along with any attachments immediately. You should not copy or use it for any purpose, nor disclose its contents to any other person.

Click [here](#) to report this email as spam.





1. future driveway access | 2. future green zone along Kennedy St (dark trees) | 3. retained car parks along Kennedy St
 4. pocket parking | 5. existing trees | 6. basement entry | 7. adjacent Abode Hotel driveway access



1. new street trees and micro parks | 2. rejuvenated public realm | 3. possible future driveway to service neighbouring block
 4. pocket park | 5. existing trees | 6. proposed driveway | 7. Abode Hotel | 8. possible future development



1. roof garden | 2. stairs / lift overruns | 3. voids
4. service | 5. waste collection









NORTH ELEVATION - KENNEDY STREET



SOUTH ELEVATION - LANEWAY

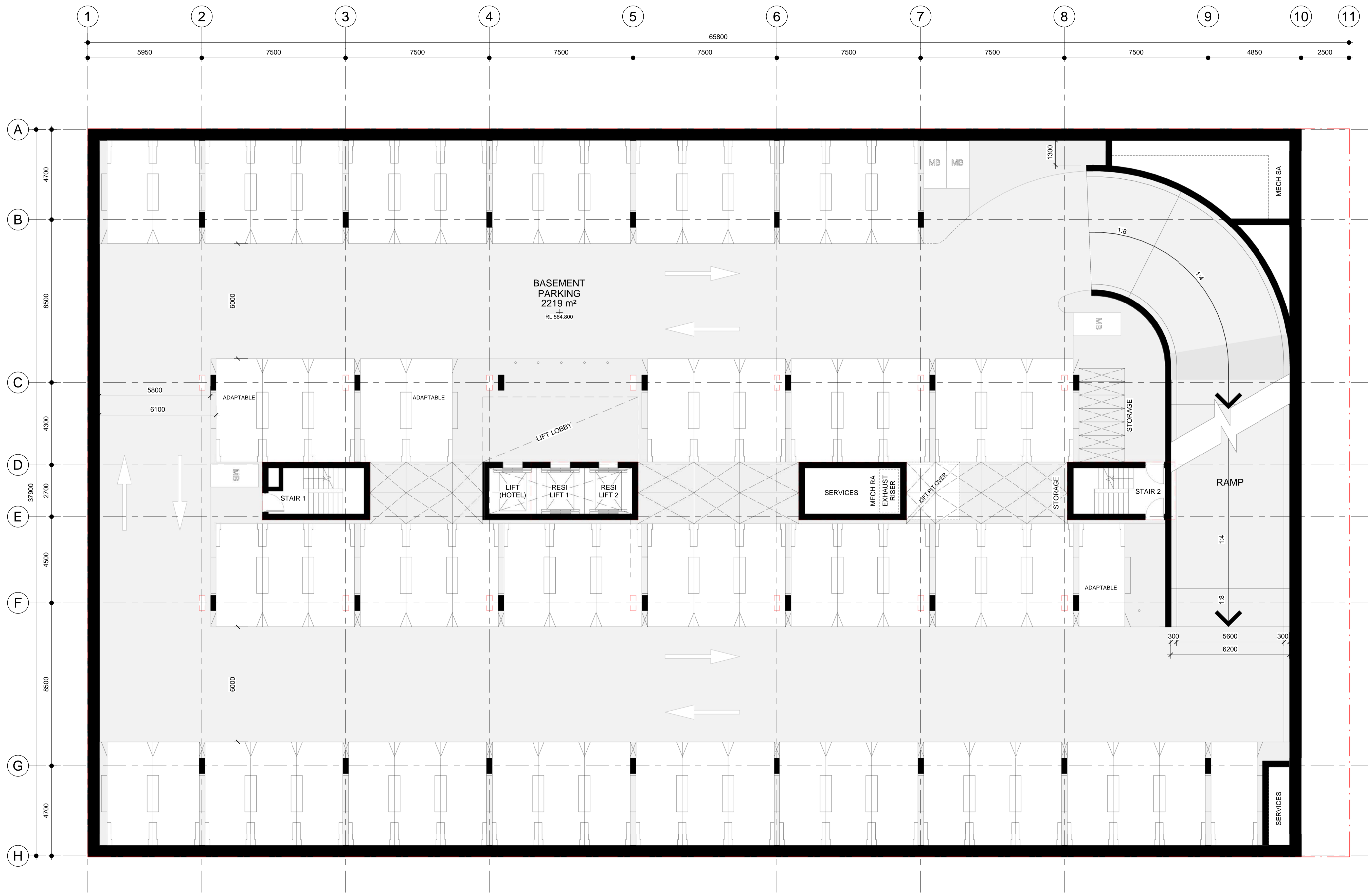

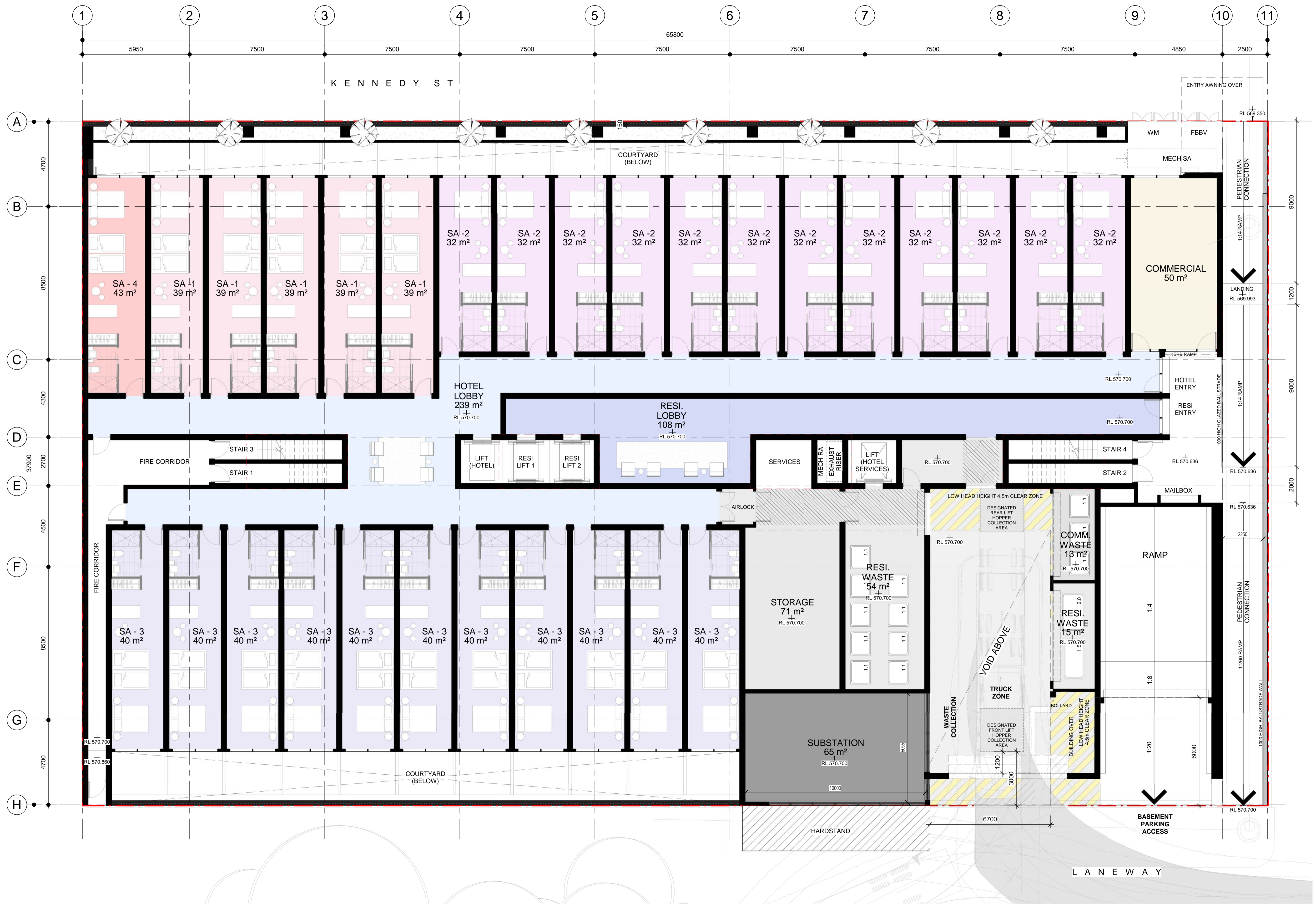

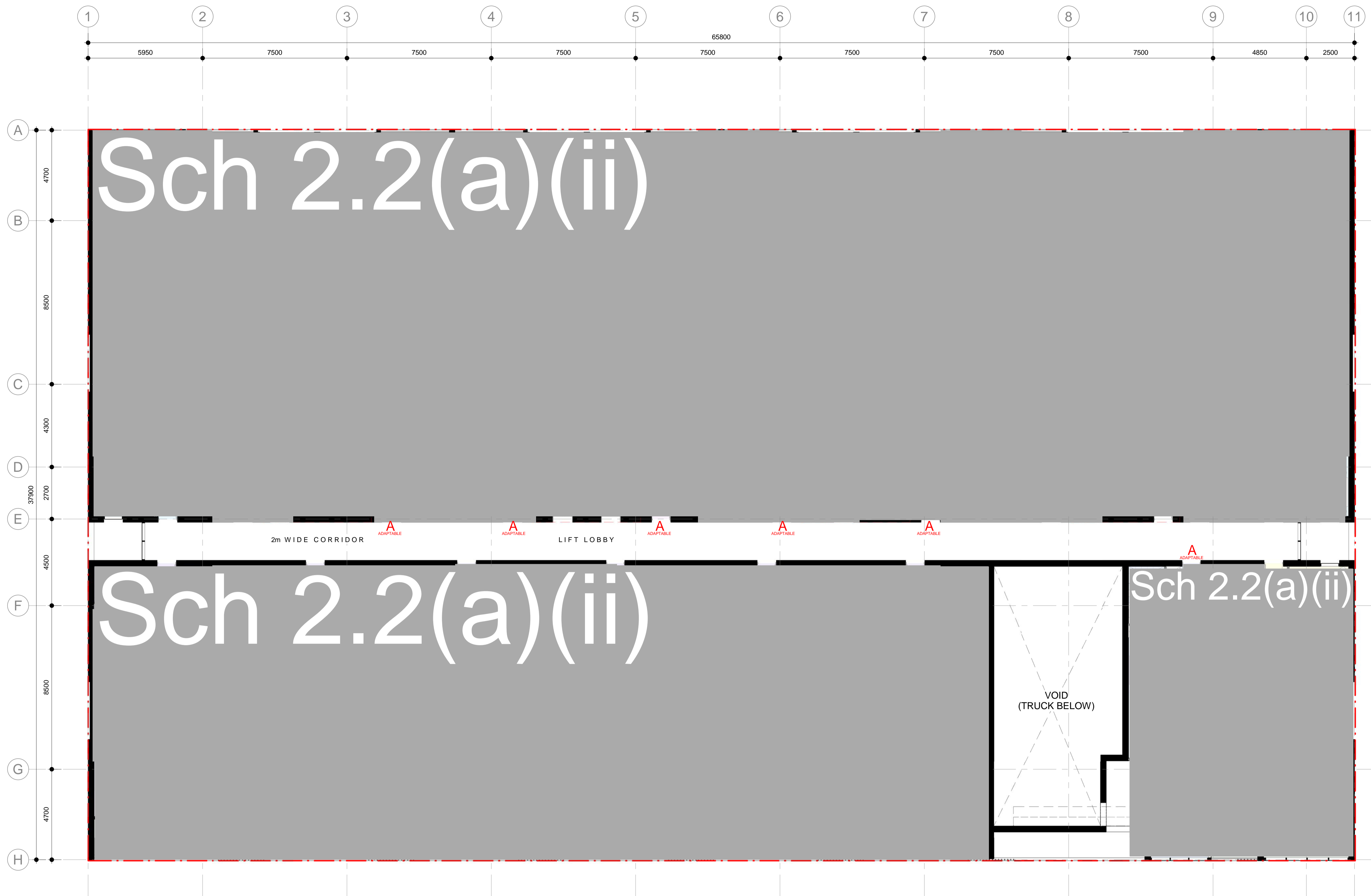

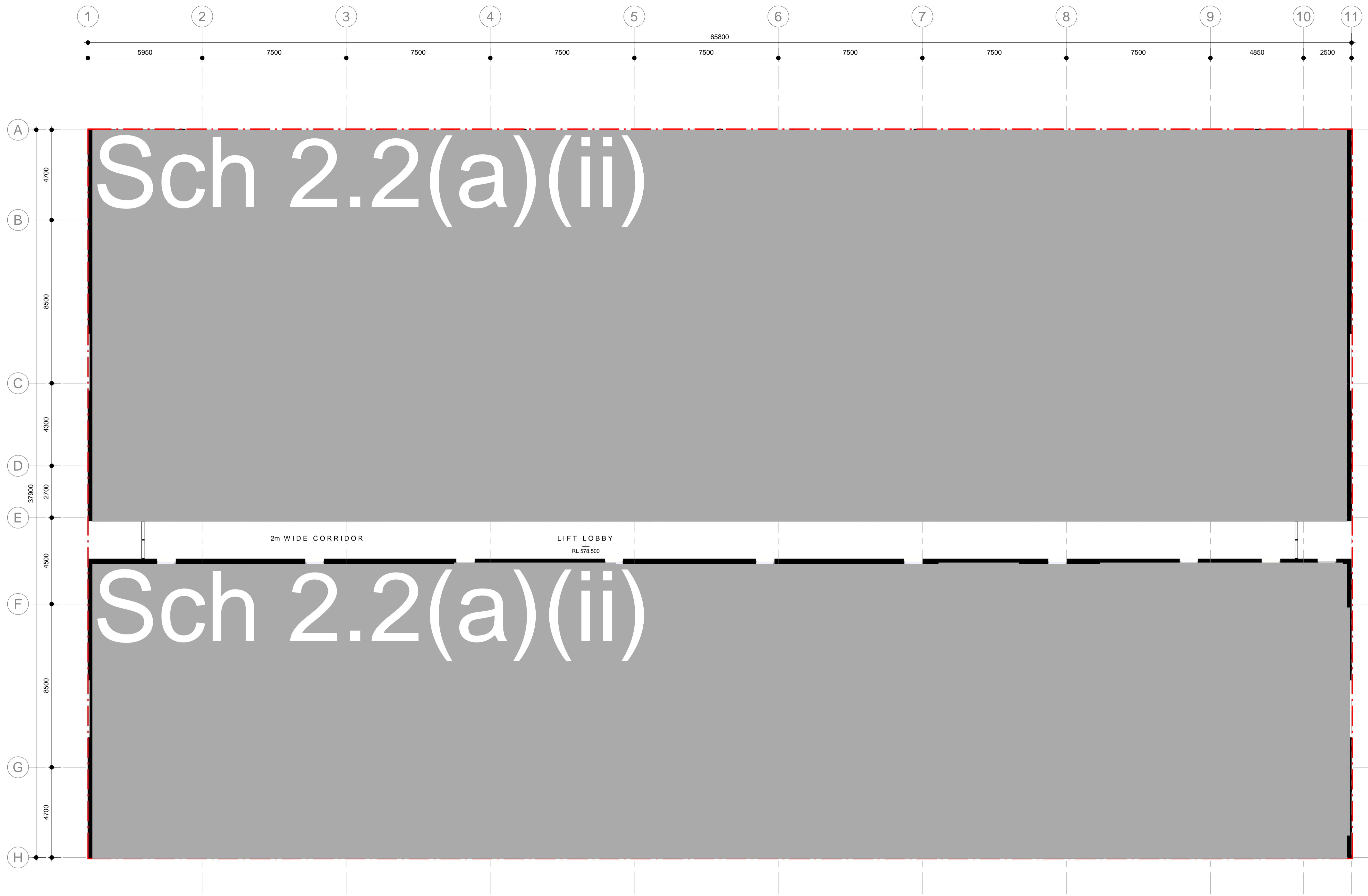

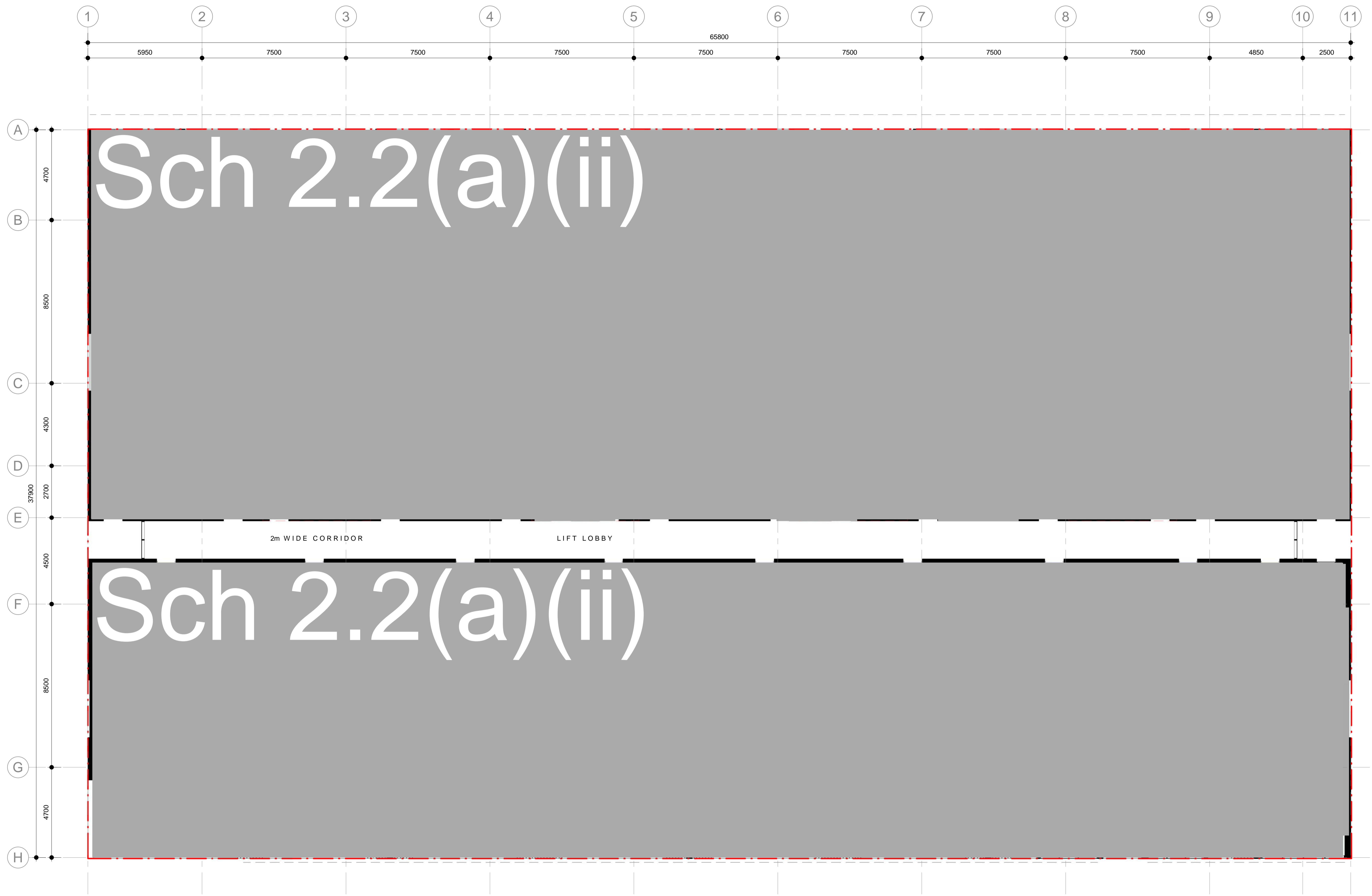

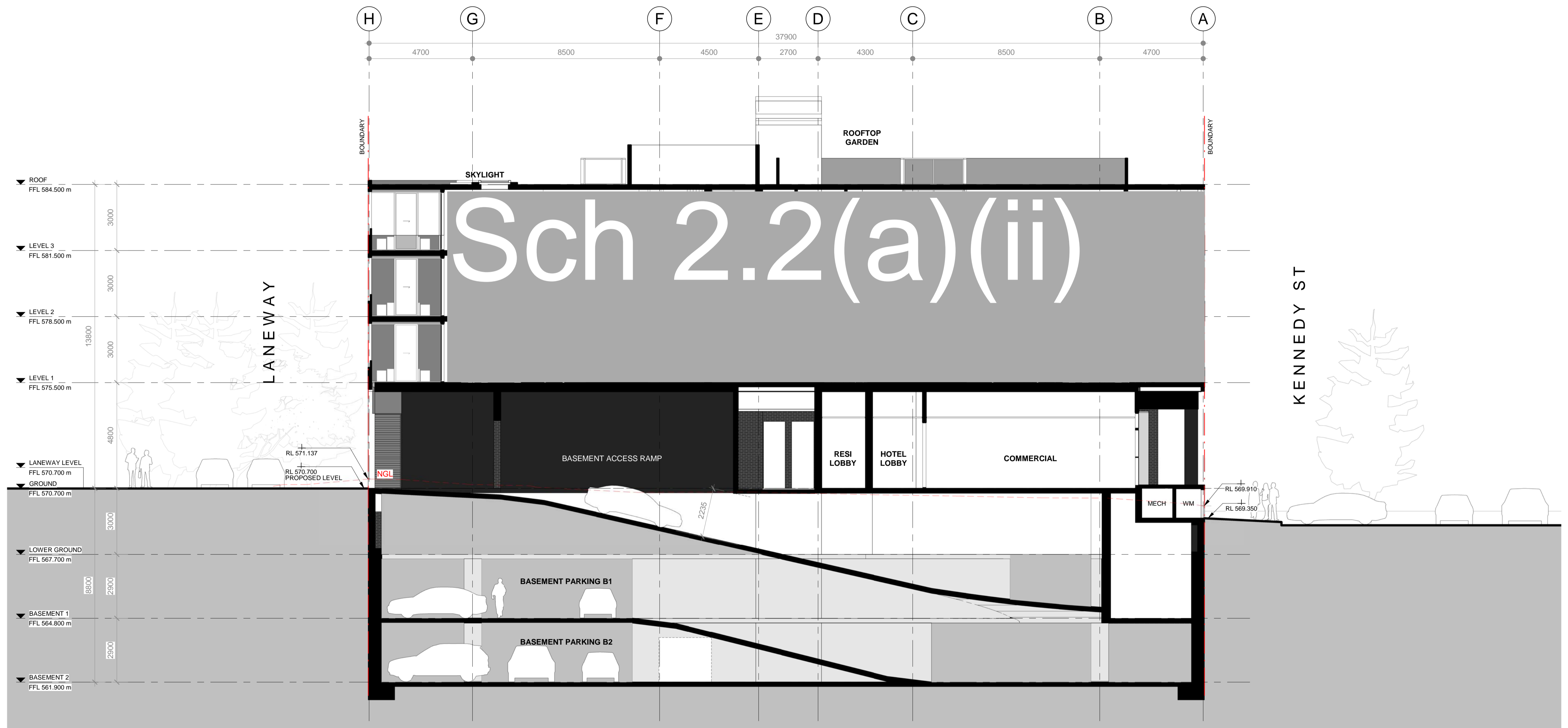

TYPICAL SECTION

From: [Gell, Chris](#)
To: [Gell, Chris](#)
Subject: 20230620-FILE NOTE- 16/20 Kingston
Date: Tuesday, 20 June 2023 2:51:18 PM
Attachments: [KennedySt_EPSDD Presentation_230531.pdf](#)

OFFICIAL

A meeting held on 31/5/23 for Zapari & Cox architects to present their development proposal for 16/20 Kingston at 480 NBA.

Trent Varlow, Matt Davis & myself attended.

Cox presented a PDF had been used to present the scheme to a community meeting.

Cox indicated the ground floor would be serviced apartments with the upper floors being residential.

Vehicle & waste access was intended to be by the rear laneway, confined to the SE side to maintain the rest of the lane as planting area.

Several issues were raised including viability of existing commercial space, extent of laneway planting to be removed, size of balconies etc.

It was intended to submit a DA for the site within the next few months.

Attached is the presentation.

Chris Gell 20/6/23

Bell, SophieA

From: Gell, Chris
Sent: Friday, 23 June 2023 11:58 AM
To: [REDACTED]
Cc: [REDACTED]
Subject: RE: 10 KENNEDY ST KINGSTON - ZAPARI REDEVELOPMENT PROPOSALproposal

OFFICIAL

Hi [REDACTED]

Thank you for the email and taking my call. As discussed, we were approached by Purdons to have a quick meeting for them to present the proposal. This provided us an opportunity to raise any obvious concerns prior to a DA being submitted.

Unfortunately we are unable to meet with the [REDACTED] to discuss the proposed development as (firstly) we don't have a DA lodged to discuss. Further, the Planning and Development Act 2007 makes it clear that anyone may make a written representation about a development application that has been notified. I think we would be on shaky ground (legally and timewise) if we provided an opportunity for every person who has concerns about any development proposal to come and meet with us to discuss those concerns.

I understand a development application is intended to be lodged within the next few months – this will be publicly notified and we would welcome all representations in that period.

Thanks

Chris

From: [REDACTED]
Sent: Wednesday, 21 June 2023 4:22 PM
To: Gell, Chris <Chris.Gell@act.gov.au>
Cc: [REDACTED]
Subject: Fwd: 10 KENNEDY ST KINGSTON - ZAPARI REDEVELOPMENT PROPOSALproposal

Caution: This email originated from outside of the ACT Government. Do not click links or open attachments unless you recognise the sender and know the content is safe. [Learn why this is important](#)

Hi Chris. I understand from [REDACTED] of Purdons that you've been involved in discussions over this project. We'd really like the opportunity to discuss this also with you and/or other relevant ACTPLA people (see below & attached).

Regards

[REDACTED]

Begin forwarded message:

From: [REDACTED]

Date: 19 June 2023 at 5:00:45 pm AEST

To: Ben Ponton <Ben.Ponton@act.gov.au>, Craig Weller <craig.weller@act.gov.au>, "Davies, Richard" <Richard.Davies@act.gov.au>

Cc: [REDACTED]

Subject: 10 KENNEDY ST KINGSTON - ZAPARI REDEVELOPMENT PROPOSALproposal

We understand from Purdons that some pre-DA discussions on this project have occurred with ACTPLA, and that concern has been expressed about the 'arched' facades originally proposed.

[REDACTED] would also be grateful for the opportunity of discussing our concerns about this project with ACTPLA.

Attached for your information is my 'Planning Assessment' of the latest version of the proposal (May 2023). Also attached is a letter sent to Purdons following our first meeting on this in February 2023. This letter has never been responded to and most of our concerns still apply to the latest version, which is essentially little changed.

In our view this proposal represents a gross overdevelopment of the site, is highly inappropriate in this location and would have unacceptable impacts on the amenity of the neighbours. Please give our concerns your close and serious consideration.

I look forward to your response.

[Redacted]

From: [Redacted]

Sent: Monday, 19 June 2023 4:44 PM

To: [Redacted]

Cc: [Redacted]

Subject: Re: Zapari Meeting (10 Kennedy St proposal)

Hi [Redacted]

Following our meeting last week I prepared the attached 'Planning Assessment' of the Zapari proposal.

Please ensure this is brought to the attention of Zapari and Cox Architects.

[Redacted]

From: [Redacted]

Sent: Wednesday, 14 June 2023 2:33 PM

To: [Redacted]

Subject: RE: Zapari Meeting (10 Kennedy St proposal)

1/19 Eastlake Parade, Kingston ACT 2604

Regards,

[Redacted]

02 6257 1511
243 Northbourne Avenue,
Lyneham ACT 2602

Dhawura nguna, dhawura Ngunnawal.

Any representation, statement, opinion or advice expressed or implied in this email is made in good faith but on the basis that Purdon Planning, its agents and employees are not liable to any person for any damage or loss whatsoever which has occurred or may occur, in relation to that person taking or not taking (as the case may be) action, in respect of any representation, statement or advice referred to in this email.

From: [REDACTED]

Sent: Wednesday, June 14, 2023 2:15 PM

To: [REDACTED]

Cc: [REDACTED]

[REDACTED]

Subject: Re: Zapari Meeting (10 Kennedy St proposal)

Hu [REDACTED]

Where at the Foreshore is Cox's office again, please?

Thank you

Cordelia

On Thu, 8 June 2023, 9:34 am [REDACTED] wrote:

I can do that [REDACTED] In the interests of not mucking about further, let's confirm the meeting is:

- 5.30pm Wednesday 14 June @ Cox's office (?) Eastlake Parade Kingston Foreshore.

[REDACTED] please invite neighbours as appropriate. We probably won't have many [REDACTED] Committee members, so hopefully the room can accommodate us all.

[REDACTED] you might be interested as well?

[REDACTED]

From: [REDACTED]

Sent: Thursday, 8 June 2023 9:23 AM

To: [REDACTED]

Cc: [REDACTED]

Subject: RE: Zapari Meeting (Kennedy St proposal)

Hi [redacted] and team,

Day and location is good, the team would like to do it at 5:30pm. Will this work?

Regards,



02 6257 1511

243 Northbourne Avenue,
Lyneham ACT 2602



purdon.com.au | [LinkedIn](#)

Dhawura nguna, dhawura Ngunnawal.

Any representation, statement, opinion or advice expressed or implied in this email is made in good faith but on the basis that Purdon Planning, its agents and employees are not liable to any person for any damage or loss whatsoever which has occurred or may occur, in relation to that person taking or not taking (as the case may be) action, in respect of any representation, statement or advice referred to in this email.

From: [redacted]

Sent: Wednesday, June 7, 2023 1:30 PM

To: [redacted]

Cc: [redacted]

Subject: Re: Zapari Meeting (Kennedy St proposal)

Hi [REDACTED] - next Wednesday (14 June) 730pm @ Cox's (Eastlake Parade)?

[REDACTED]

[REDACTED]

On 6 Jun 2023, at 3:04 pm, [REDACTED] wrote:

Hi [REDACTED]

Its looking likely that it will be a next week event, Zapari would also like to propose the meeting be held at Cox as it is more neutral and in Kingston.

I would suggest I will get a flip flop response the more I discuss with them so, when able, if you and the [REDACTED] team work out when you can do it next week let me know and I will propose it to the group.

Happy to chat over the phone if needed.

Regards,



02 6257 1511

<image001.png>

243 Northbourne Avenue,
Lyneham ACT 2602

purdon.com.au | [LinkedIn](#)

Dhawura nguna, dhawura Ngunnawal.

Any representation, statement, opinion or advice expressed or implied in this email is made in good faith but on the basis that Purdon Planning, its agents and employees are not liable to any person for any damage or loss whatsoever which has occurred or may occur, in relation to that person taking or not taking (as the case may be) action, in respect of any representation, statement or advice referred to in this email.

From: [Redacted]
Sent: Tuesday, June 6, 2023 12:57 PM
To: [Redacted]
Cc: [Redacted]
Subject: RE: Zapari Meeting

Thanks [Redacted]

Thursday works for me, I can check with the team. Zapari are located at Manuka Village, Bougainville St in Manuka.

Regards,

[Redacted]

02 6257 1511

<image001.png>

[Redacted]

243 Northbourne Avenue,
Lyneham ACT 2602

purdon.com.au | [LinkedIn](#)

Dhawura nguna, dhawura Ngunnawal.

Any representation, statement, opinion or advice expressed or implied in this email is made in good faith but on the basis that Purdon Planning, its agents and employees are not liable to any person for any damage or loss whatsoever which has occurred or may occur, in relation to that person taking or not taking (as the case may be) action, in respect of any representation, statement or advice referred to in this email.

From: [Redacted]
Sent: Tuesday, June 6, 2023 12:08 PM
To: [Redacted]
Cc: [Redacted]
Subject: Re: Zapari Meeting

Hi [Redacted] Where are Zapari located? I could do tomorrow or Thursday evenings this week, but would need to check with others.

[Redacted]

On 6 Jun 2023, at 11:42 am, [Redacted] wrote:

Hi [redacted]

Zapari are happy to host as well. They would prefer to meet earlier than Thursday next week, but please let me know if the Thursday 15th at Eastlake is preferred.

Regards,



02 6257 1511

<image001.png>

243 Northbourne Avenue,
Lyneham ACT 2602

purdon.com.au | [LinkedIn](#)

Dhawura nguna, dhawura Ngunnawal.

Any representation, statement, opinion or advice expressed or implied in this email is made in good faith but on the basis that Purdon Planning, its agents and employees are not liable to any person for any damage or loss whatsoever which has occurred or may occur, in relation to that person taking or not taking (as the case may be) action, in respect of any representation, statement or advice referred to in this email.

From: [redacted]

Sent: Monday, June 5, 2023 5:03 PM

To: [redacted]

Cc: [redacted]

Subject: RE: Zapari Meeting

Thanks [REDACTED],

I have informed the team.

Regards,



02 6257 1511

<image001.png>

243 Northbourne Avenue,
Lyneham ACT 2602

purdon.com.au | [LinkedIn](#)

Dhawura nguna, dhawura Ngunnawal.

Any representation, statement, opinion or advice expressed or implied in this email is made in good faith but on the basis that Purdon Planning, its agents and employees are not liable to any person for any damage or loss whatsoever which has occurred or may occur, in relation to that person taking or not taking (as the case may be) action, in respect of any representation, statement or advice referred to in this email.

From: [REDACTED]

Sent: Monday, June 5, 2023 4:27 PM

To: [REDACTED]

Cc: [REDACTED]

Subject: Re: Zapari Meeting

Hi [REDACTED] Eastlakes can accomodate us (MacDonald Room) Thursday 15 June from 7.30 pm.

I'll check who's available from the [redacted]



On 5 Jun 2023, at 3:36 pm, [redacted] wrote:

Thanks for the prompt reply, I will let the project team know and will let you know asap.

Regards,



02 6257 1511

<image001.png>

243 Northbourne Avenue,
Lyneham ACT 2602

purdon.com.au | [LinkedIn](#)

Dhawura nguna, dhawura Ngunnawal.

Any representation, statement, opinion or advice expressed or implied in this email is made in good faith but on the basis that Purdon Planning, its agents and employees are not liable to any person for any damage or loss whatsoever which has occurred or may occur, in relation to that person taking or not taking (as the case may be) action, in respect of any representation, statement or advice referred to in this email.

From: [REDACTED]
Sent: Monday, June 5, 2023 3:09 PM
To: [REDACTED]
Cc: [REDACTED]
Subject: Re: Zapari Meeting

Hi [REDACTED] Our June Committee meeting was last Thursday. Our next scheduled one is 6 July. I could do the next two Wednesdays or Thursdays for a special meeting, depending on the availability of other Committee members and a room, preferably at Eastlakes Club.



On 5 Jun 2023, at 2:39 pm, [REDACTED] wrote:

Hi [REDACTED]

The architect has put together a revised scheme and the consultant team are working to finalise inputs before submission. Zapari has informed me they wish to present back to [REDACTED]

Would you be able to suggest any suitable times/dates for such a presentation?

Regards,



02 6257 1511

<image001.png>

243 Northbourne Avenue,
Lyneham ACT 2602

purdon.com.au | [LinkedIn](#)

Dhawura nguna, dhawura Ngunnawal.

Any representation, statement, opinion or advice expressed or implied in this email is made in good faith but on the basis that Purdon Planning, its agents and employees are not liable to any person for any damage or loss whatsoever which has occurred or may occur, in relation to that person taking or not taking (as the case may be) action, in respect of any representation, statement or advice referred to in this email.

From: [Redacted]

Sent: Wednesday, April 12, 2023 3:30 PM

To: [Redacted] >

Cc: [Redacted]

Subject: Re: Zapari Meeting

Thanks [Redacted]. We'll assume you won't attend the [Redacted] Committee meeting tomorrow night. Unfortunately (!) I'll be overseas most of May so our next meeting will probably be 1 June.





From: [Redacted]
Sent: Wednesday, 12 April 2023 3:01 PM
To: [Redacted]
Cc: [Redacted]
Subject: RE: Zapari Meeting

Hi [Redacted]

I haven't heard from the client at all.

Regards,



02 6257 1511

<image001.png>

243 Northbourne Avenue,
Lyneham ACT 2602

purdon.com.au | [LinkedIn](#)

Dhawura nguna, dhawura Ngunnawal.

Any representation, statement, opinion or advice expressed or implied in this email is made in good faith but on the basis that Purdon Planning, its agents and employees are not liable to any person for any damage or loss whatsoever which has occurred or may occur, in relation to that person taking or not taking (as the case may be) action, in respect of any representation, statement or advice referred to in this email.

From: [REDACTED]
Sent: Monday, 3 April 2023 2:06 PM
To: [REDACTED]
Cc: [REDACTED]
Subject: Re: Zapari Meeting

[REDACTED] - we have decided to defer the [REDACTED] Committee meeting from this Thursday to the following one (13 April) for various reasons.

We probably won't have one in May because I'm O/S most of the month.



On 27 Mar 2023, at 4:16 pm, [REDACTED] wrote:

OK thanks



On 27 Mar 2023, at 4:14 pm, [redacted] wrote:

Hi [redacted]

Appreciate the update from you. In short, I am unsure about timeframes due to a delay from the architects, but [redacted] is still interested in meeting.

The project's design team are still working on the design, I would suggest that when we have finalised this, we will be in touch. At this stage it would be prudent to allow some time for [redacted] to come and discuss at the next meeting. I should have a better indication by the end of this week whether it will work out this way.

I'm sorry for the run-around but this is the most up-to-date information I have on this right now.

Regards,



02 6257 1511

<image001.png>

243 Northbourne Avenue,
Lyneham ACT 2602

purdon.com.au | [LinkedIn](#)

Dhawura nguna, dhawura Ngunnawal.

Any representation, statement, opinion or advice expressed or implied in this email is made in good faith but on the basis that Purdon Planning, its agents and employees are not liable to any person for any damage or loss whatsoever which has occurred or may occur, in relation to that person taking or not taking (as the case may be) action, in respect of any representation, statement or advice referred to in this email.

From: [Redacted]

Sent: Monday, 27 March 2023 4:08 PM

To: [Redacted]

Subject: Re: Zapari Meeting

Hi [Redacted] What's happening on Kennedy Street? We have another [Redacted] Committee meeting coming up next week - **7.30** pm Thursday 6 April.



On 16 Feb 2023, at 10:54 am, [redacted] wrote:

Thanks [redacted]

I have passed on your suggestions and hope to get a response back soon.

Regards,



02 6257 1511

<image001.png>

243 Northbourne Avenue,
Lyneham ACT 2602

purdon.com.au | [LinkedIn](#)

Dhawura nguna, dhawura Ngunnawal.

Any representation, statement, opinion or advice expressed or implied in this email is made in good faith but on the basis that Purdon Planning, its agents and employees are not liable to any person for any damage or loss whatsoever which has occurred or may occur, in relation to that person taking or not taking (as the case may be) action, in respect of any representation, statement or advice referred to in this email.

From: [REDACTED]

Sent: Wednesday, 15 February 2023 5:15 PM

To: [REDACTED]

Cc: [REDACTED]

Subject: Re: Zapari Meeting

Yes [REDACTED] Any suggested times? I'm usually out Fridays and Tuesday mornings. Next week, I won't be in town Monday-Wednesday.

We have our next [REDACTED] Committee meeting coming up on Thursday 2 March at Eastlakes. That's probably the best time to get most of the Committee. Is that too late for [REDACTED]? We could possibly have a special meeting next Thursday evening (23 Feb). (I'm going to suggest we start our meetings later, say 7.30pm).



From: [REDACTED]
Sent: Wednesday, 15 February 2023 3:49 PM
To: [REDACTED]
Cc: [REDACTED]
Subject: Zapari Meeting

Hi [REDACTED]

[REDACTED], the owner of Zapari wishes to have a meeting with you [REDACTED] committee to discuss the Kennedy Street project.

Please let me know if you and/or your committee are interested.

Regards,



02 6257 1511

<image001.png>

243 Northbourne Avenue,
Lyneham ACT 2602

purdon.com.au | [LinkedIn](#)

Dhawura nguna, dhawura Ngunnawal.

Any representation, statement, opinion or advice expressed or implied in this email is made in good faith but on the basis that Purdon Planning, its agents and employees are not liable to any person for any damage or loss whatsoever which has occurred or may occur, in relation to that person taking or not taking (as the case may be) action, in respect of any representation, statement or advice referred to in this email.