



ENVIRONMENT PROTECTION GUIDELINES FOR  
CONSTRUCTION AND LAND DEVELOPMENT IN THE ACT

Environment Protection Authority | March 2011

© Australian Capital Territory, Canberra 2011

This work is copyright. Apart from any use as permitted under the *Copyright Act 1968*, no part may be reproduced without the written permission of the Environment Protection Authority, GPO Box 158, Canberra ACT 2601

Published by Publishing Services for the Department of the Environment, Climate Change, Energy and Water

Publication No: 11/0190

Enquiries: Phone Canberra Connect on 13 22 81

Website: [www.environment.act.gov.au](http://www.environment.act.gov.au)

Printed on 100% recycled paper

---

# CONTENTS

---

<b>1</b>	<b>INTRODUCTION</b>	<b>1</b>
	1.1 Purpose of Guidelines	1
	1.2 Principles of Pollution Control	1
	1.3 Quick Guide for Required Approvals	2
<b>2</b>	<b>LEGISLATION AND POLICY</b>	<b>3</b>
	2.1 <i>Environment Protection Act 1997</i> (the Act)	3
	2.2 Environmental Protection Agreement and Environmental Authorisation	3
	2.3 <i>Water Resources Act 2007</i>	4
	2.4 Responsibility for Pollution Control Installation and Maintenance	5
	2.5 Legal Requirements	5
<b>3</b>	<b>MANAGEMENT OF PARTICULAR ACTIVITIES</b>	<b>6</b>
	3.1 Land Development - Subdivisions	6
	3.2 Road Projects	8
	3.3 Underground Utilities	8
	3.4 Channels and Floodways	9
	3.5 Ponds and Dams	10
	3.6 Medium Density Housing Projects/Commercial Buildings	10
	3.7 Single Residential Blocks	11
<b>4</b>	<b>EROSION AND SEDIMENT CONTROL MEASURES</b>	<b>12</b>
	4.1 Vegetative Cover	12
	4.2 Stabilised Access Point	13
	4.3 Earthworks	14
	4.4 Diversion of Surface Water	15
	4.5 Level Spreader	18
	4.6 Sediment Control Pond	19
	4.7 Sediment Trench	22
	4.8 Sediment Pit	23
	4.9 Sediment Traps for Channelled Run-Off	23
	4.10 Sediment Control Barrier	27
	4.11 Stockpile Management	29
	4.13 Stormwater Inlet Protection	29
<b>5</b>	<b>SPECIALISED EROSION AND SEDIMENT CONTROLS</b>	<b>31</b>
	5.1 Works Within A Waterway	31
	5.2 Temporary Waterway Crossing	31
	5.3 Portable Sediment Tank	33
	5.4 Downdrain Structure (Slope Protection Structure)	33
	5.5 Trenches	34

<b>6</b>	<b>NOISE</b>	<b>36</b>
<b>7</b>	<b>AIR QUALITY</b>	<b>37</b>
	7.1 Dust	37
	7.2 Fire	37
<b>8</b>	<b>SPOIL MANAGEMENT</b>	<b>38</b>
	8.1 Disposal of Spoil	38
	8.2 Acceptance of Soil	38
<b>9</b>	<b>REFERENCES</b>	<b>40</b>
<b>10</b>	<b>GLOSSARY OF TERMS</b>	<b>41</b>
<b>11</b>	<b>SCHEDULES</b>	<b>45</b>
	Schedule 11.1 Minimum Standards for Submission of Pollution Control Plans	45
	Schedule 11.2 Daily Environmental Maintenance Checklist	46
	Schedule 11.3 Water Discharge Table	47
<b>12</b>	<b>NOTES</b>	<b>48</b>

---

# 1 INTRODUCTION

---

## 1.1 Purpose of Guidelines

These guidelines have been prepared to provide guidance on the Environment Protection Authority's preferred methods for pollution control design, construction, operation and maintenance. The adoption of appropriate pollution controls during construction and land development activities is important not only to the environment but also the developer/builder. A development without adequate pollution controls increases costs e.g. replacing washed away stockpiles, clean up costs, fines and a loss of your businesses reputation.

### **Erosion and Sediment Control**

Without erosion and sediment protection measures, large amounts of soil can be lost from a building site and enter the stormwater system. The stormwater system drains directly into our waterways. Sediment in our waterways pollutes our creeks, lakes and rivers and has a major impact on water quality, aquatic plants and animals.

### **Noise**

Construction and land development activities can generate levels of noise ranging from being a nuisance to actually damaging people's health.

### **Air Quality**

Mismanagement of air quality on site has the potential to result in detrimental effects on the health and amenity of neighbours and employees, reduced visibility on site, increased wear on machinery and equipment and complaints from neighbours.

### **Spoil Management**

Placing contaminated material on your land can harm the environment by polluting waterways, destroying vegetation and contaminating land, and may leave you with an expensive clean-up bill.

## 1.2 Principles of Pollution Control

These guidelines will assist in determining the pollution control measures most appropriate for the commonly experienced situations in the ACT. The recommended approach is based on the following principles of pollution control.

### **Erosion and Sediment Control**

- Plan erosion and sediment controls early in the land development process and incorporate the cost into the works program.
- Install controls prior to commencement of earthworks and maintain until revegetation is fully established.
- Divert run-off from above the site to a stable disposal area.
- Establish a stable drainage system through the site before other construction activities commence.

- Minimise surface disturbance to retain the maximum area of natural vegetation cover.
- Install sediment control ponds and sediment traps to contain sediment on sites over 1 hectare.
- Chemically dose turbid water prior to discharge from the site.
- Maintain erosion and sediment control structures.
- Establish vegetation as soon as practical on all areas where soil has been exposed.

### Noise

- Ensure all building work that generates noise is conducted within the time periods detailed in Schedule 2 of the Environment Protection Regulation 2005.

### Air Quality

- Incorporate measures to limit affect on air quality by minimising dust from construction activities and smoke from fires.

### Spoil Management

- The EPA must be notified before disposing spoil off site or accepting soil on site. In some cases, an Environmental Authorisation may be required. See Section 8 for more information.

These guidelines have been produced to assist builders and developers meet their responsibilities under the *Environment Protection Act 1997* and the Environment Protection Regulation 2005. However these guidelines are not mandatory and professional judgement should be used on the suitability of these guidelines for the known site conditions. Information contained within these guidelines does not replace the need for site-specific evaluation, testing and design where it is judged necessary. Pollution control measures not described in these guidelines may be utilized providing all practicable and reasonable steps are taken to minimise pollution.

For more specific information in relation to pollution control on residential building sites, refer to 'Prevent Pollution from Residential Building Sites Best Practuce Guidelines', Information Sheets 1–6.

## 1.3 Quick Guide for Required Approvals

Environmental Protection Agreement	3
Environmental Authorisation	3
Constructing a Sediment Control Pond	17
Dewatering of Sediment Control Pond	19
Works Within a Waterway	30
Spoil Management	36
Pollution Control Plan Checklist	41

Contact the Environment Protection Authority by calling Canberra Connect on 13 22 81.

---

## 2 LEGISLATION AND POLICY

---

### 2.1 *Environment Protection Act 1997 (the Act)*

The Act provides the regulatory framework to protect the environment from pollution and its effects. The Act establishes the Environment Protection Authority (EPA) as the statutory decision maker for environmental regulation and policy. The EPA administers legislation covering air and water quality, waste, contaminated land, noise control and hazardous chemicals.

Under the Act people in the ACT have a general environmental duty that requires them to take such steps that are practicable and reasonable to prevent or minimise environmental harm or environmental nuisance. There is also a legal obligation to notify the EPA of any actual or threatened environmental harm.

### 2.2 **Environmental Protection Agreement and Environmental Authorisation**

It is a requirement under the Act to obtain an Environmental Protection Agreement or an Environmental Authorisation for land development or construction activities on sites of 0.3 ha or greater, prior to works commencing.

An Environmental Protection Agreement covers all sites, is valid for three years and requires no fee. An Environmental Authorisation covers all sites, is reviewed annually and requires an application fee and an annual fee. An Environmental Authorisation may be granted for an unlimited period. Both the Environmental Protection Agreement and Environmental Authorisation address erosion and sediment control, noise and air pollution issues and spoil management for commercial developments of 0.3 ha or greater. Plans will need to be provided to the EPA for each commercial development addressing these issues. The plans should be considered at the design stage for in principle approval prior to tenders being called in order to allow contractors to incorporate the cost of pollution control measures.

The plans for a site of 0.3 to 1 ha should include:

- proposed activities;
- existing topography including contour lines, catchment boundaries, catchment areas, adjacent areas including creeks and buildings;
- approximate amount, source and/or destination of spoil to be imported/exported at the site;
- location of permanent stormwater inlets, pipes, outlets and other permanent drainage facilities;
- vegetative buffer areas to be protected by fencing;
- details of proposed pollution control measures in accordance with these guidelines; and

- proposed timetable for construction activities; installation of pollution controls; and surface stabilisation measures.

The plans for a site over 1 ha should include:

- proposed activities;
- existing topography including contour lines, catchment boundaries, catchment areas, adjacent areas including creeks and buildings;
- approximate amount of soil to be imported/exported at the site;
- existing and final drainage patterns;
- proposed shaping;
- staging of the development;
- limits of clearing and grading, including vegetative buffer areas to be fenced off;
- details and specification of proposed pollution control measures including retention ponds, spillways, outlet pipes, diversion channels and sediment traps;
- location of permanent stormwater inlets, pipes, outlets and other permanent drainage facilities;
- proposed timetable for construction activities; installation of pollution controls; and
- surface stabilisation measures including seeding and mulching rates.

In addition to the above controls, sites over 1 ha must have a sediment control pond of adequate size constructed to control all runoff from the site (i.e. 150 cubic metres per hectare of catchment). Site drawing and details must be provided to the EPA for approval prior to works commencing. A checklist of what should be included in the drawing and details is located at Schedule 11.1.

If spoil is to be transported on or off site ensure the EPA is notified. Refer to Section 8.

### **2.3 Water Resources Act 2007**

The *Water Resources Act 2007* is a law that controls how we can access and use water directly from waterbodies including groundwater in the ACT. It provides a framework for the sustainable management of the Territory's water resources.

It aims to:

- protect waterways and groundwater aquifers from damage;
- ensure that water resources are available to meet needs of future generations; and
- protect the ecosystems that depend on those resources.

The *Water Resources Act 2007* prescribes which activities must be licensed for water use. This includes the construction of a dam 2 ML or larger; the construction or alteration of a bore; the taking water from a waterbody or bore;

and construction or alteration of structures that affect flows in a waterway. This does not include taking of mains water.

## **2.4 Responsibility for Pollution Control Installation and Maintenance**

The developer/builder in control of the property has the responsibility to ensure that pollution control measures are in place before work commences and are adequately maintained throughout construction.

The developer/builder must ensure all workers (including subcontractors, delivery drivers, etc) are aware of their responsibilities to minimise pollution.

All workers must comply with their general environmental duty under the Environment Protection Act and the Environment Protection Regulation 2005.

## **2.5 Legal Requirements**

Under the Environment Protection Act, it is an offence for a person to allow any substance other than rainwater to enter the stormwater system. Contraventions of the Act can lead to an on-the-spot fine of up to \$200 for an individual and \$1000 for a company. More serious offences can lead to penalties of up to \$50,000, six months in jail and a criminal record.

In the case of excessive noise a complaint may be lodged with the EPA. A complaint regarding noise pollution will be considered by the EPA, only if it is made by a person affected by the noise. The EPA will undertake an investigation which may include issuing a warning letter, on-the-spot fine, or depending on the circumstances, an Environment Protection Order. If the noise continues to be a problem, it is a serious offence and could lead to prosecution in court.

In relation to air pollution, under the Act, it is an offence for a person to cause an environmental nuisance. Contraventions of the Act can lead to a \$100 fine or to penalties of up to \$25,000.

## 3 MANAGEMENT OF PARTICULAR ACTIVITIES

---

### 3.1 Land Development - Subdivisions

Subdivisions require the most comprehensive design approach and use of most of the available recognised soil erosion control measures. The developer's design professional shall determine the control measures most appropriate for the site and for the nature of the works.

Normally sediment control ponds and any critical diversions will be the first priority of work and must be in place prior to commencement of general clearing, stripping, earthworks and hydraulic works. Large site areas should be divided into separate parts as a means of limiting the extent of exposed areas, and for implementing progressive stabilisation of works.

#### **Considerations at the design stage**

Plan the development to fit the site.

- Assess the physical characteristics of the site to determine how it can be developed with the smallest risk of environmental damage.
- Minimise land reshaping by using the existing topography wherever possible.

Determine limits of land clearing and shaping.

- Decide exactly which areas must be disturbed to accommodate the proposed construction, and which areas can remain untouched.
- Pay special attention to critical areas (for example, steep slopes, highly erodible soils, surface water borders, wetlands and the like).
- Consider staged clearing and construction as an alternative to mass clearing and construction.
- Fence off the areas which should remain undisturbed.

Divide the site into natural drainage areas.

- Determine how run-off will drain from the site.
- Remember that it is more advantageous to control erosion at the source and prevent problems than to design perimeter controls to trap sediment.
- Consider how erosion and sedimentation can be controlled in each small drainage area or sub-catchment before looking at the entire site.
- Identify stable and preferred water disposal areas.

Select pollution control practices.

- Determine erosion and sediment control measures appropriate for the site in accordance with:
  - this Guideline;
  - Volume 1 of Managing Urban Stormwater: Soils and Construction, Landcom, 2004, (the Blue Book); or
  - other guidelines approved or endorsed by the EPA.

- Include key dimensions and specifications in construction details.
- Liaise as necessary with the EPA and obtain agreement to the adequacy of the proposed measures.
- Construct and maintain structural measures in accordance with standards and specifications set out in this Guideline, the Blue Book or other guidelines approved or endorsed by the EPA.
- Incorporate measures to ensure all building work that generates noise takes place within the time periods detailed in Schedule 2 of the Environment Protection Regulation 2005.
- Incorporate measures to limit affect on air quality.

The following controls apply to Subdivisions:

- Use diversion structures to convey upstream run-off to a stable disposal area. Stabilise diversion works.
- Provide off-stream sediment control ponds prior to discharge of run-off into the main drainage system.
- The pond must be located within the subdivision unless otherwise approved by the EPA.
- Discharge from sediment control ponds is only allowed when water pH is 6.5-8.5 and is clarified to below 60 mg/litre suspended solids (50 Nephelometric Turbidity Units (NTU)).
- Water level in a sediment control pond must be maintained at 20% capacity so runoff from the next rain event can be captured.
- Temporary sediment control ponds shall not be removed until 85% of the developments are complete, or all disturbed areas are stabilised.
- Topsoil should be stockpiled separately (not greater than 2 metres high) from general excavated material and stabilised. The topsoil may then be re-spread over disturbed areas.
- Maintain as much vegetative cover as practical particularly beside main drainage lines. Fence off these buffer areas to prevent disturbance.
- Stage works to limit the extent of exposed and unprotected areas.
- Maintain strict site access control with a stabilised access point that all vehicles must use. In addition, assign a designated parking area.
- Regularly remove any sediment from roads adjacent to the work area. Do not wash into the stormwater system.
- Install sediment traps at drainage inlets and other points of discharge from areas of disturbance.
- Install permanent drainage facilities at an early stage.
- Undertake temporary or permanent vegetative stabilisation measures immediately after completion of final land forming.
- Establish alternative stable drainage systems through the site while permanent facilities are being installed.
- Protect all cut and fill batters from run-off and stabilise immediately after construction.

- Use contour ploughing and/or surface roughening of finished landform over all disturbed blocks as an aid to stabilisation and to slow water flow during rain events.
- Maintain pollution control measures during construction and until full stabilisation.

### 3.2 Road Projects

Road projects are linear developments that could cross a number of drains and water courses, therefore, measures appropriate to this characteristic need to be adopted. The design professional shall determine the most suitable control measures for each site.

The following controls or specific principles apply to road projects:

- Divert clean water away from disturbed area. Ensure it is diverted to a stabilised area. Install permanent drainage in first stages.
- Culverts are to be installed prior to constructing embankments.
- Limit extent of exposed and unprotected areas by preserving existing groundcover. Progressively construct and stabilise to minimise area of exposure.
- Limit movement of construction equipment by fencing off critical areas.
- Use diversion drains and earth banks to carry run-off away from disturbed areas.
- Stockpile topsoil separately (not greater than 2 metres high) from general excavated material. Respread over disturbed areas. The depth of topsoil on cut and fill batters should not be greater than 5–10 cm.
- Windrows of soil must not be left on the sides of roads following construction.
- Use downstream sediment traps (see Section 4.9), upstream interceptors and diversions as well as controlled run-off conveyance.
- Stormwater inlet protection measures should be installed.
- Install permanent drainage structures and road table drains with sediment traps at completion of initial earthworks.
- Protect all cut and fill batters from run-off and stabilise immediately following construction.
- Maintain pollution control measures during construction and until full stabilisation.
- Following construction all disturbed areas must be seeded and straw mulched.

### 3.3 Underground Utilities

Underground utilities are also a linear development that may cross a number of drains and watercourses and appropriate control measures need to be implemented.

The following controls or specific principles apply to the installation of underground utilities (also see 5.5 Trenches):

- Excessive trench widths or depths shall be avoided. Limit construction equipment activity to disturbed areas.
- Wherever possible, spoil should be placed on the far side and uphill of the trench away from the stormwater system.
- Stockpile topsoil separately (not greater than 2 metres high) from general excavated material. Respread over disturbed areas. After backfilling, excess or unsuitable spoil should be removed from the site. The spoil disposal location should be detailed on the pollution control plans. A pollution control plan checklist is located at Schedule 11.1.
- Excavations shall be left open for the minimum practical time and shall not be opened for a greater length than pipes can be laid in a day. Progressively construct work and stabilise.
- If the trench needs to be pumped dry, the discharge water should be chemically dosed before discharge if not of an acceptable standard. See Section 4.7.
- Run-off from works shall be passed through sediment controls.
- Where on-site controls are not practical, the stormwater system, water channels or bodies of water shall be protected from sediment laden run-off.
- Where pipes are to be laid across a stream bed, stream diversions are required. See Section 5.1.
- For vehicular access across a watercourse or works crossing a watercourse temporary waterway crossings are required. See Section 5.2.
- Supervisory staff involved in excavation work shall ensure that their employees or contractors understand and follow the above requirements.
- Maintain pollution control measures during construction and until full stabilisation.
- Regularly remove any sediment from roads adjacent to the work area. Do not wash into the stormwater system.

### 3.4 Channels and Floodways

Channels and floodways can be the most difficult works to control and stabilise.

The design professional shall specify suitable pollution control measures for each site. The following general controls and principles apply to the construction of channels and floodways:

- Undertake pollution control works as first priority in order to stabilise against and ahead of upper catchment development.
- Use diversion structures to convey upstream run-off away from the site to a stable disposal area. Stabilise diversion works.
- Stockpile topsoil separately (not greater than 2 metres high) from other excavated material for respreading over disturbed areas.
- Limit construction equipment activity and provide for limited access.

- Progressively construct works and stabilise with the aid of mulch, jute mesh, matting and turfing immediately after construction.
- Use sediment traps and diversions to limit erosion potential. See Section 4.9.
- Maintain all control measures during construction.

### 3.5 Ponds and Dams

Ponds and dams are generally constructed as initial infrastructure works; are generally located downstream of major urban development; and are designed to protect downstream water quality. A large pond or dam (2ML or larger); a pond or dam to be located on a waterway; and any structure that may affect flow in a waterway may require a permit under Section 44 of the *Water Resources Act 2007* to construct. Contact the EPA for more information.

The design professional shall specify suitable control measures for each site. The following general controls apply to the construction of dam and pond projects:

- Divert clean water away from disturbed area. Ensure it is diverted to a stabilised area.
- Direct discharge from basin excavation works into a pond such as a cofferdam and chemically dose before discharge if not of an acceptable standard. See Section 4.6.
- Disperse and slow discharge flow by using spreaders and/or other erosion and sediment controls.
- Divert run-off from embankment and spillway areas into a sediment control pond. Chemically dose before discharge if not of acceptable standard.
- Stockpile topsoil at the start of project (not higher than two metres) and respread over disturbed areas when works are complete.
- Stabilise downstream batter of embankment and spillway area immediately on completion.
- Maintain all control measures during construction and until stabilisation.

### 3.6 Medium Density Housing Projects/Commercial Buildings

These are more limited development projects than subdivisions and are more akin to large building sites. The builder or design professional shall determine the most suitable pollution control measures to ensure that no sediment leaves the site or pollutes the stormwater system.

The following controls apply to medium density housing projects and commercial buildings:

- Limit the area of disturbance and undertake temporary or permanent stabilisation immediately upon completion of the works.
- Restrict vehicle entry to a stabilised access point.

- Assign a designated parking area.
- Divert clean water away from disturbed area. Ensure it is diverted to a stabilised area on site.
- Install a sediment control barrier around the lower end of the site to prevent sediment discharge.
- Protect the stormwater system with sediment control measures.
- Consider the use of a sediment control pond, sediment basin, sedimentation tank or sump pit for turbidity control.
- Stockpile topsoil at the start of the project (not greater than 2 metres high). Respread over disturbed areas.
- Maintain all control measures during construction and until full stabilisation.
- Regularly remove any sediment from roads adjacent to the site. Do not wash into the stormwater system.
- Design an area for the washout of concrete trucks.

### **3.7 Single Residential Blocks**

- Maintain as many grassed areas as possible particularly on the verges to trap soil before it reaches the roadway and stormwater system. Fence off undisturbed areas.
- Use only one exit/entry to the site. Build a stabilised access point by using road base, 50mm aggregate, recycled concrete or similar.
- Assign a designated parking area.
- Limit access to the site during and immediately after wet weather.
- Keep stockpiles within the site area and away from the stormwater system.
- Install onsite waste collection.
- Regularly remove any sediment from roads adjacent to your site. Do not wash into the stormwater system.
- Install a sediment control barrier of geotextile fabric on the low side/s of the block.
- Designate a brick cutting and wash area away from stormwater drains. Ensure the area is large enough to contain all excess water, residues and waste.
- Regularly check and maintain pollution controls throughout construction.

## 4 EROSION AND SEDIMENT CONTROL MEASURES

Regardless of whether the measures are temporary or permanent, sediment control measures should be the first items constructed when work begins, and be completely functional before up-slope land disturbance takes place. Earth structures such as diversion drains and earth banks should be stabilised before being considered functional.

It is necessary for the contractor to appoint a staff person to be responsible for maintaining the pollution control measures. The controls should be inspected at the end of each day and after any significant rainfall event and be quickly repaired as necessary. Structures using material that have a short life, such as straw bales shall be replaced regularly. See Schedule 11.2

The following is a description of the most commonly used control measures.

### 4.1 Vegetative Cover

The maintenance and re-establishment of vegetation are the most important factors in minimising erosion during development. Vegetation shields the soil surface from raindrop impact while the root mass holds soil particles in place. Grass buffer strips can be used to filter sediment from surface run-off.

#### Vegetative Buffers

The maintenance of vegetation adjacent to water bodies, wetlands and other areas of natural resource value is essential to ensure such areas are not adversely effected by construction or by stormwater run-off once construction is completed. However, during construction, vegetative buffers on their own are not sufficient sediment and erosion control measures.

To ensure that such areas are not adversely affected by construction or by stormwater run-off once construction is completed, the following design criteria should be followed.

<i>Slope %</i>	<i>Buffer Strip Length</i>
2	15 m
4	20 m
6	30 m
8	40 m
10	50 m
12	60 m
14	70 m

## Revegetation

Stabilisation measures may be temporary or permanent and should be applied within 14 days of disturbance and/or final earthworks shaping. Progressive stabilisation should be incorporated and specified in the pollution control plans. Temporary measures typically should not be used if the soil is to remain exposed for more than 60 days.

Where sites are unlikely to be successfully vegetated using broad area techniques, it is necessary to adopt specialised methods of establishing vegetation. These methods include straw mulching, bitumen spraying, hydromulching, hydroseeding, turfing and the use of other meshes and mattings. Situations where they would be applicable are on excessively steep slopes, drainage lines currently operating and requiring immediate cover, areas where topsoil is absent and cannot be applied and sowing during periods where seasonal conditions are unfavourable.

Refer to the Blue Book for standards and specification for vegetative stabilisation of channels and steep slopes.

## 4.2 Stabilised Access Point

A stabilised access point consists of a stabilised pad of aggregate underlain with geotextile fabric located at any point where traffic will be entering or leaving a construction site at a public road, street, open space or parking area. Limit to one entry/exit point where possible.

**Figure 1: Stabilised Access Point**

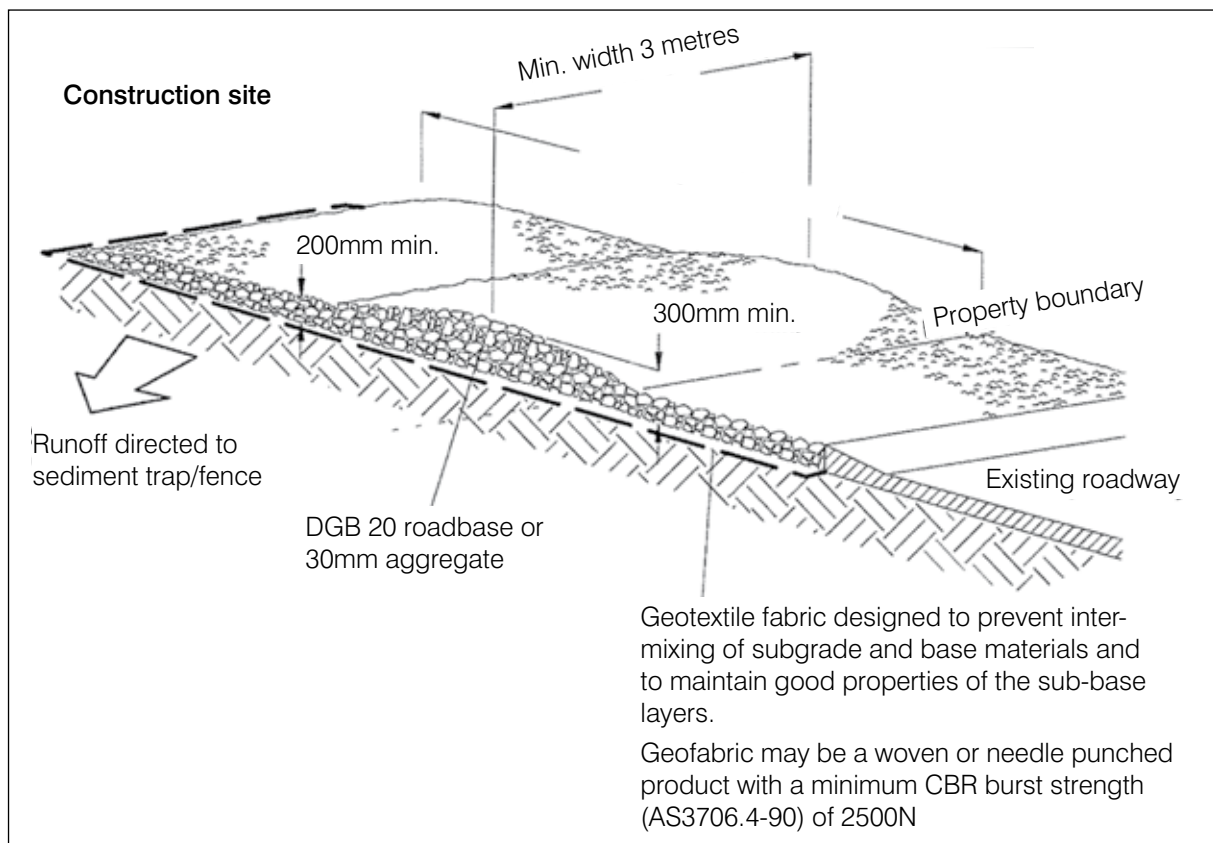

### **Design Criteria**

If possible, choose an access site in an elevated position with little or no water runoff from upslope. The appropriate location for construction access may not always be the proposed driveway location.

- Remove top layer of soil at least 3 m wide from the road to the construction site.
- Use road base or 50 mm aggregate or recycled concrete or equivalent to a depth of 150-200 mm with an underlay of heavy-duty geotextile fabric cloth.
- Where the pad slopes toward the road, install a 300 mm high bund (hump) across the pad to divert stormwater runoff to a sediment fence for filtering.

### **Maintenance**

The stabilised access point shall be maintained in a condition which will prevent tracking of sediment onto roads. All sediment on roads must be removed immediately. Check the stabilised access at the end of each day and before a rain event. Monitor for compaction from vehicles and add aggregate or equivalent as required.

### **Grid/Vehicle Wash Bay**

Where there is more significant and heavier traffic, the use of a grid or vehicle wash bay may be necessary. Design the grid or vehicle wash bay so that the water that leaves the area does not enter the stormwater system. The grid or vehicle wash bay should be lifted and cleared out periodically. Grids and vehicle wash bays should be followed by stabilised material to ensure that vehicles do not carry mud off-site.

## **4.3 Earthworks**

Earth moving equipment and trafficking by heavy equipment exposes the soil and subjects it to high erosive potential. All access must be controlled on the site and vehicles and plant must keep to well defined haul roads to minimise ground disturbance and compaction.

Stockpiles should be stored outside hazard areas such as drainage lines. If necessary, diversions should be installed up slope to divert run-on.

In general, it is important to leave soil surfaces on disturbed slopes in a roughened condition (contoured striations or furrows) and to construct a water diversion at the top of the slope. Rough soil surfaces do not erode as easily as smooth soil surfaces.

### 4.4 Diversion of Surface Water

Diversion of surface water is important because it:

- Prevents clean water from getting dirty or turbid by diverting run-off from undisturbed up-slope areas away from disturbed areas. Diversion drains, earth banks, upstream perimeter diversions or other diversions that outlet in stable areas can be used in this capacity.
- Diverts sediment laden run-off to sediment controls.
- Reduces the length of a slope into non-erosive segments so that soil loss will be reduced.

Diversion works must be designed and constructed in a manner that will not erode or cause erosion.

#### Earth Bank (Low Flow)

An earth bank is a berm or ridge of compacted earth located in such a manner as to channel water to a desired location. An earth bank can be constructed with or without an excavated drainage channel.

**Figure 2: Earth Bank (Low Flow)**

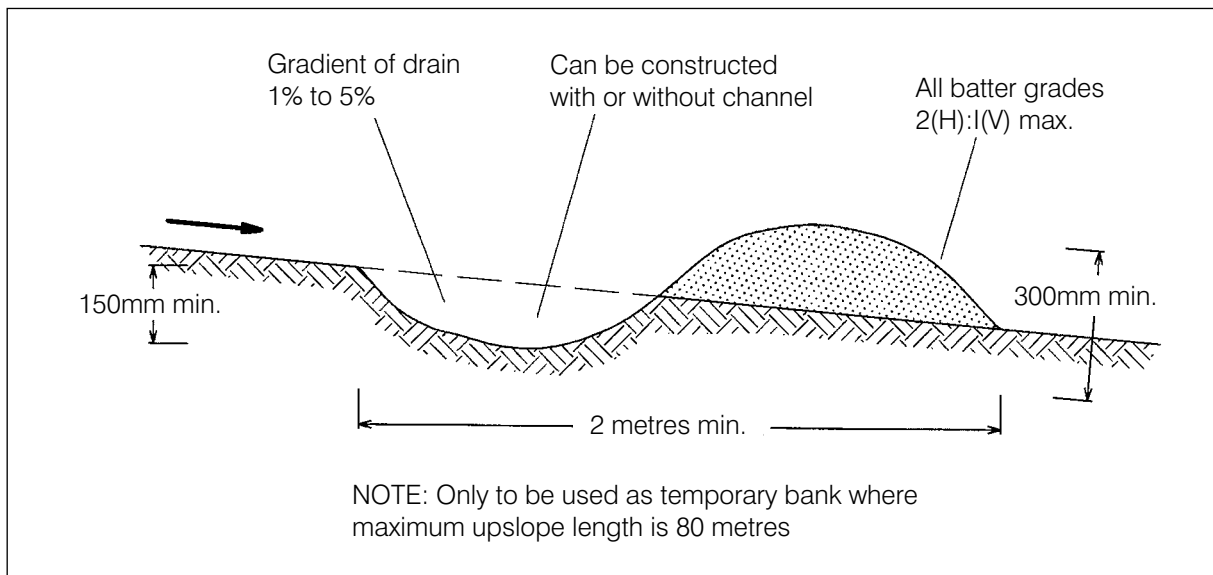

Illustration reproduced courtesy of Landcom.

#### Design Criteria—Earth bank (Low Flow)

Drainage Area	< 1 Ha	1-2 Ha	2-4 Ha
Bank Height	0.5 m	0.5 m	0.75 m
Bank Width	1.5 m at bottom	0.6 m at crest	1 m at crest
Side Slopes	1:2 or flatter	1:2 or flatter	1:2 or flatter

**Design criteria—Channel**

<i>Drainage Area</i>	<i>&lt; 1 Ha</i>	<i>1-2 Ha</i>	<i>2-4 Ha</i>
Width of flow channel	0.6 m	1 m	2 m
Depth of flow channel	0.3 m	0.3 m	0.3 m
Side Slopes	1:2 of flatter	1:2 or flatter	1:2 or flatter

**Stabilisation of Channel**

The disturbed area of the bank shall be stabilised within 14 days of installation according to the following criteria.

<i>Channel Grade</i>	<i>&lt; 2 Ha</i>	<i>2-4 Ha</i>
0.5-3.0%	Seed and straw mulch	Seed and straw mulch
3.1-5.0%	Seed and straw mulch	Seed and cover with jute or similar and spray with bitumen, sod or line with 50mm aggregate
5.1-8.0%	Seed and cover with jute or similar and spray with bitumen, sod or line with 50mm aggregate	Line with 100-200 stone or recycled concrete equivalent
8.1-10%	Line with 100-200 stone or recycled concrete equivalent	Engineering design

**Earth Bank (High Flow)**

High Flow Earth Banks are drainage channels of parabolic or trapezoidal cross-section with a supporting ridge on the lower side that is constructed across the slope. The purpose is to intercept and convey run-off from the drainage areas of up to 10 Ha to stabilised outlets.

Design earth banks in relation to velocity and capacity in accordance with the Blue Book. Peak discharge of run-off values used in determining capacity requirements should be calculated using the Blue Book.

The inverts of the channels should be stabilised in accordance with the Blue Book. The discharge from a diversion drain should be via a level spreader or piped diversion.

**Figure 3: Earth Bank (High Flow) Type 1**

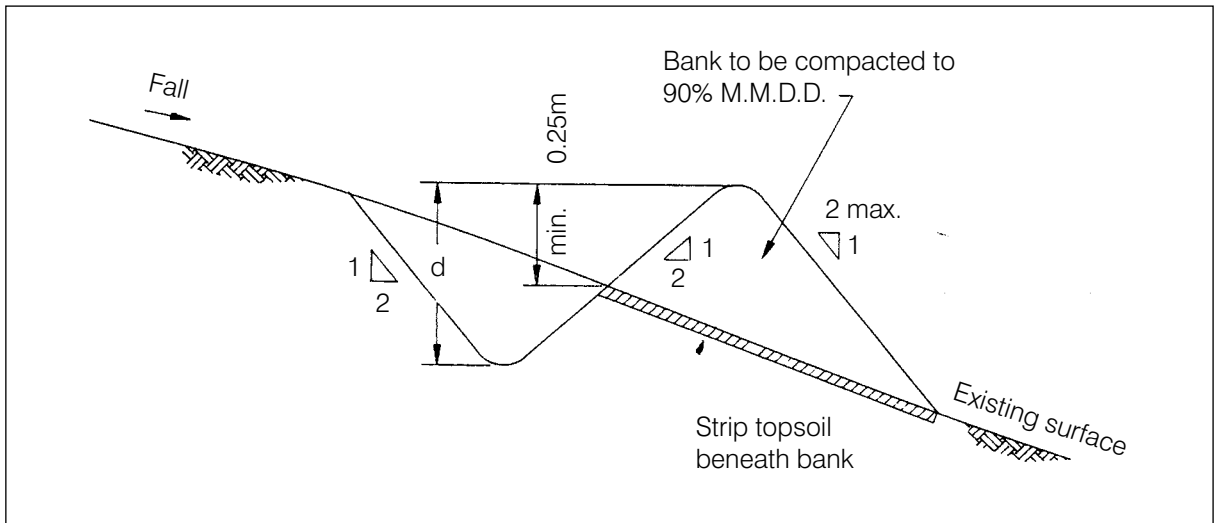

**Figure 4: Earth Bank (High Flow) Type 2**

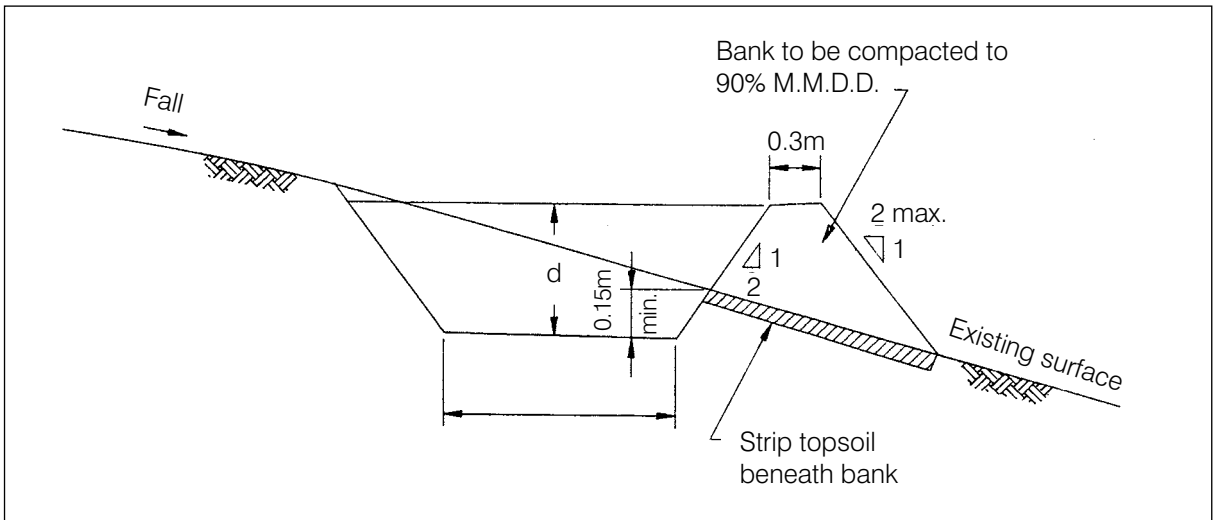

**Design criteria**

Dimensions of channel in relation to channel slope and catchment area are outlined in the following tables.

**Earth Bank (High Flow) Type 1** (parabolic—for smaller catchments)—  
Depth (d) in metres

Channel Slope %	0.5 Ha (d)	1 Ha (d)	2 Ha (d)	5 Ha (d)
0.5	0.2	0.3	0.35	0.45
1.0	0.2	0.25	0.3	0.4
2.0	0.2	0.2	0.3	0.35
5.0	0.15	0.2	0.25	-
10.0	0.15	0.15	-	-

**Earth Bank (High Flow) Type 2** (Trapezoid—for larger catchments)—  
Width (w) and Depth (d) metres

<i>Channel Slope %</i>	<i>0.5 Ha</i>		<i>1 Ha</i>		<i>2 Ha</i>		<i>5 Ha</i>	
	<i>(w)</i>	<i>(d)</i>	<i>(w)</i>	<i>(d)</i>	<i>(w)</i>	<i>(d)</i>	<i>(w)</i>	<i>(d)</i>
0.5	1	0.15	1	0.2	1	0.3	1	0.4
1.0	1	0.1	1	0.15	1	0.25	1	0.35
2.0	1	0.1	1	0.15	1	0.2	1	0.3
5.0	1	0.1	1	0.1	1.5	0.15	3	0.2
10.0	1	0.1	1.5	0.1	3.0	3.0	5	0.1

#### 4.5 Level Spreader

The purpose of a level spreader is to convert a concentrated flow of sediment free run-off (eg. diversion outlets) into sheet flow and to discharge it onto areas stabilised by vegetation without causing erosion.

The level spreader is used only in those situations where the spreader can be constructed on undisturbed soil; where the area directly below the level lip is stabilised, preferably by existing vegetation; where the drainage area above the spreader is stabilised by existing vegetation; and where the water will not be reconcentrated immediately below the point of discharge. They are used to terminate a diversion drain or earth bank or to distribute gully flow where this is undertaken.

The design criteria for level spreader shall be a maximum of 0.1 cumecs per metre of length based on the peak rate of flow from a 10 year frequency (1:10 AEP) rainfall event. Sill length depends on contributing catchment and slope and ground conditions and can be determined from the Blue Book. In any case, the minimum length shall be 4m and the maximum length shall be 25m.

**Figure 5: Level Spreader**

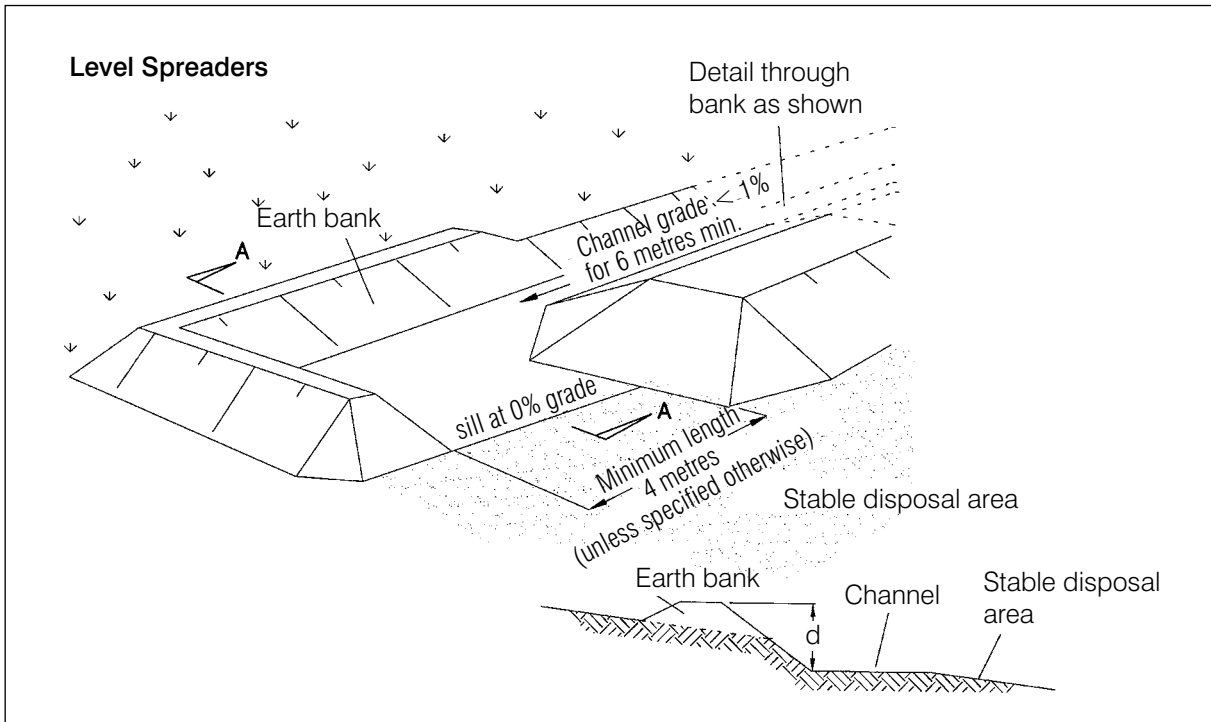
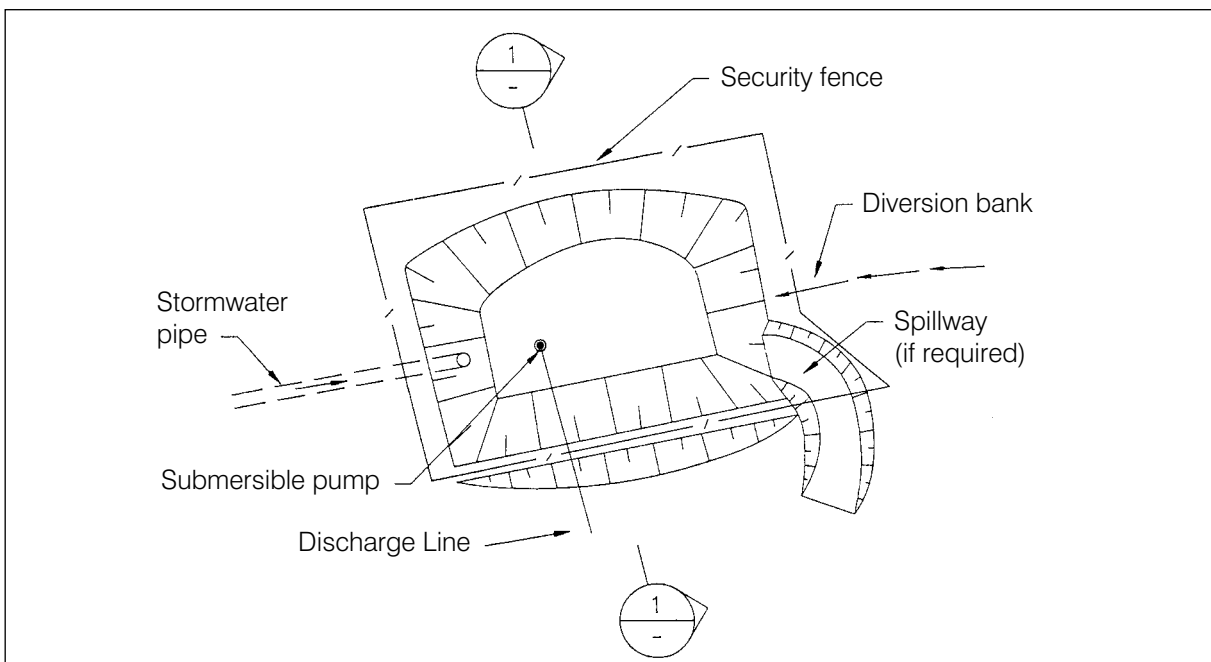

Illustration reproduced courtesy of Landcom

#### 4.6 Sediment Control Pond

A sediment control pond is a temporary or permanent storm capture device consisting of a barrier or dam or an in-ground basin constructed across the drainage outlet to intercept sediment laden run-off and to trap and retain sediment. You may require a permit under Section 44 of the *Water Resources Act 2007* to construct. Contact the EPA for more information.

**Figure 6: Sediment Control Pond**

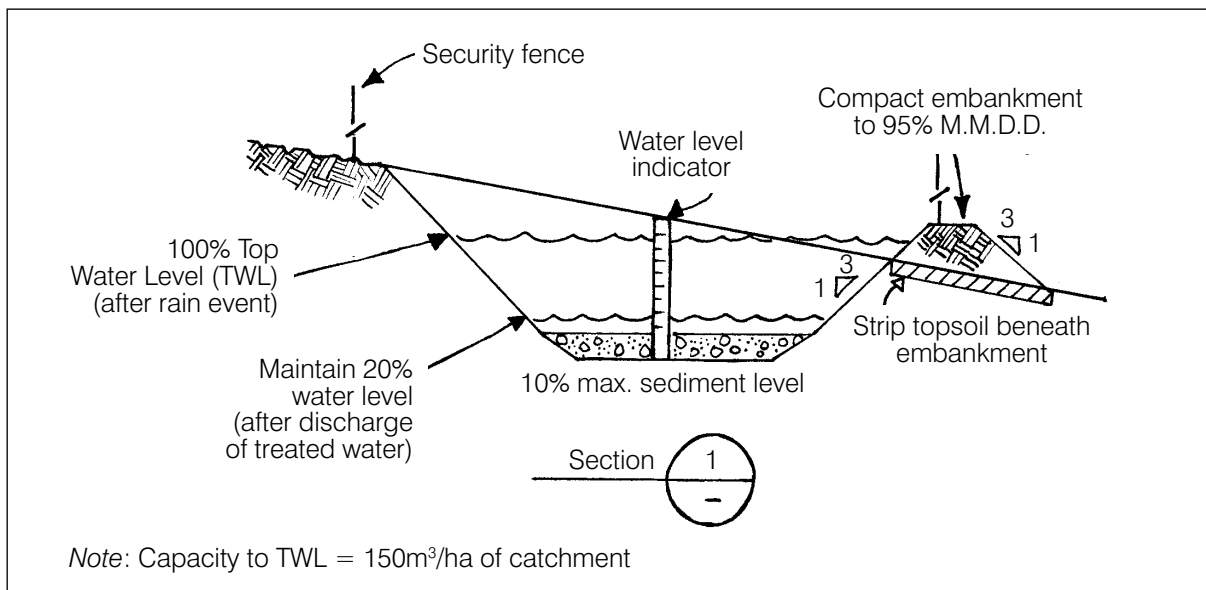

**Figure 7: Sediment Control Pond**

The sediment control pond should be located to obtain the maximum storage benefit from the terrain, and for ease of cleanout of the trapped sediment. The pond/s shall be monitored and maintained on a daily basis throughout construction and shall not be removed until 85% of the development is complete, or all the disturbed areas are stabilised.

### Design Criteria

The standards and specifications of the pond including basin, outlet, spillways and embankment are to be in accordance with the Blue Book. Install a water level indicator identifying “sediment at 10% capacity” and “water at 20% capacity”.

### Capacity

The drainage area should not exceed 40 Ha. The volume of the sediment control pond shall be at least 150 cu m per Ha of total drainage area.

Sediment build-up shall be cleaned out when it is above the 10% water level indicator. Water should be maintained at 20% capacity.

### Stabilisation

Stabilise the embankment and emergency spillway in accordance with the appropriate vegetative standards and specifications immediately following construction (i.e. grassed, jute mesh, mulch and bitumen spray). In no case shall the embankment remain unstabilised for more than 7 days after completion. Points of entrance of surface run-off into excavated sediment control ponds shall be protected to prevent erosion.

Length to width ratio should be greater than 2:1, where length is the distance between the inlet and outlet. A wedge shape is preferred with the inlet located at the narrow end. However, it is accepted that it will need to be fitted into the available land.

## Safety

Care shall be taken to keep basin slopes below water level to 1 in 4. The need for fencing can then be reviewed.

## Dewatering the Pond

Manage water so dosing and discharge can be achieved in a timely manner before the next rain event. Water should be chemically dosed and discharged when it is above 20% of the pond's full capacity (indicated by the 20% water level indicator which was installed when the pond was constructed).

Water should be chemically dosed with gypsum to accelerate settlement of suspended solids. Gypsum may be mixed either in a tank or tanker or into a slurry in a concrete mixer and then distributed to several points in the basin by a spray or spreading technique. Spraying over the surface is preferred and in-dam mixing may be required. Gypsum dosing rate should be applied at about 30 kilograms per 100 cubic metres of stored water. In some instances higher rates may apply, typically less than 50 mg/Litre. If dosing with alum, ensure it is done in accordance with the Blue Book.

Discharge from the pond is permissible when the water pH is 6.5-8.5 and is clarified to at or below 60mg/L (50 NTU) for urban areas and for other areas on the advice of the EPA. Clarification would generally be achieved within a period of 24–36 hours.

Dewatering shall be done in such a manner as to remove the relatively clean water without removing any of the sediment that has settled out and without removing any appreciable quantities of floating debris. The pump should be monitored at all times during pumping to ensure sediment is not being disturbed, creating turbid water. If water exceeds 60mg/L (50 NTU) during dewatering, pumping must cease immediately and further treatment should be carried out before pumping is recommenced. Records must be kept of all measurements prior to, during and after discharge. See Schedule 11.3.

**Figure 8: Dewatering of Pond**

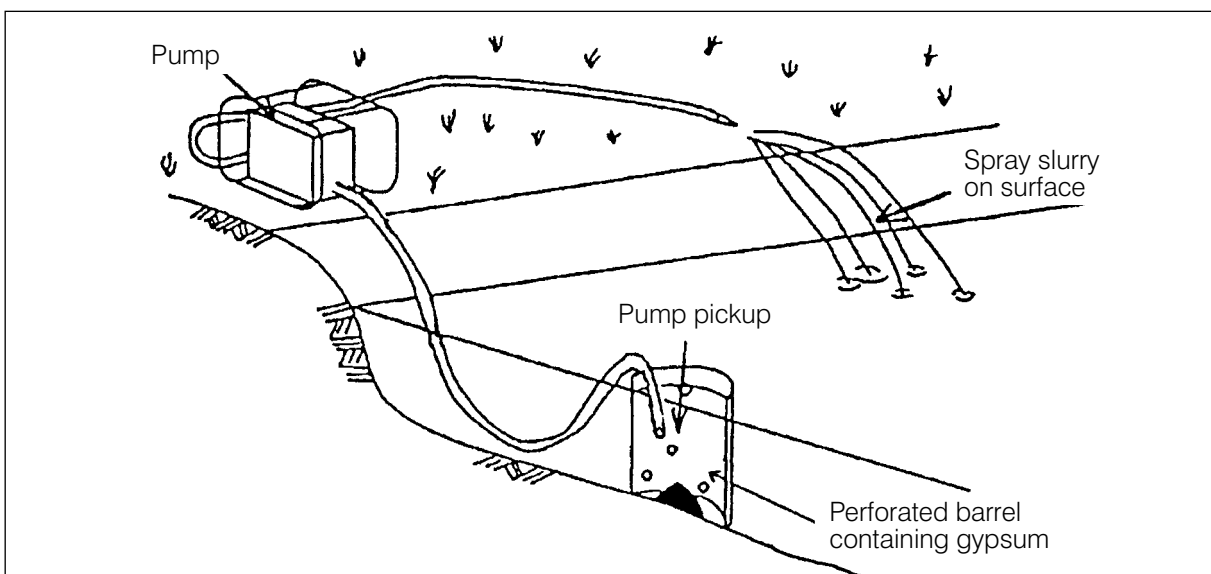

Illustration reproduced courtesy of Landcom

### **Outlet**

A gravity outlet pipe is to be utilised with a floating arm to select top water and avoid picking up sediment. Pumping out of a sediment control pond may be acceptable if a gravity solution is not practicable.

## **4.7 Sediment Trench**

A sediment trench is a temporary structure to contain polluted run-off for treatment prior to discharge. Sediment trenches are applicable to smaller sites particularly where the surface is relatively flat.

Trenches are generally at the lowest end of the site situated such that it can receive all polluted run-off.

Trenches should be less than 1 metre deep and constructed along the contour to maximise capacity. For difficult sites more than one trench may be required.

Discharge from the trench is permissible when the water pH is 6.5-8.5 and is clarified to at or below 60mg/L (50 NTU) for urban areas and for other areas on the advice of the EPA. Gypsum dosing rate should be applied at about 30 kilograms per 100 cubic metre of stored water. In some instances higher rates may apply, typically less than 50 mg/Litre. If dosing with alum, ensure it is done in accordance with the Blue Book.

Manage water so dosing and discharge can be achieved in a timely manner before the next rain event. Water should be discharged when it is above 20% of the trench's full capacity. Records must be kept of all measurements prior to, during and after discharge. See Schedule 11.3.

## **4.8 Sediment Pit**

Sediment pits are constructed to contain polluted run-off for treatment prior to discharge. They can be permanent structures which form part of a future sub-soil or stormwater drainage system. This technique is applicable to small sites (<0.5Ha) with limited open space.

Sediment pits are located at the lowest end of a piped system and the lowest point within the site. Where contained within a stormwater system, the inlet pipe should be substantially higher than the base of the sediment pit. The future outlet would not be connected until upstream areas are stabilised.

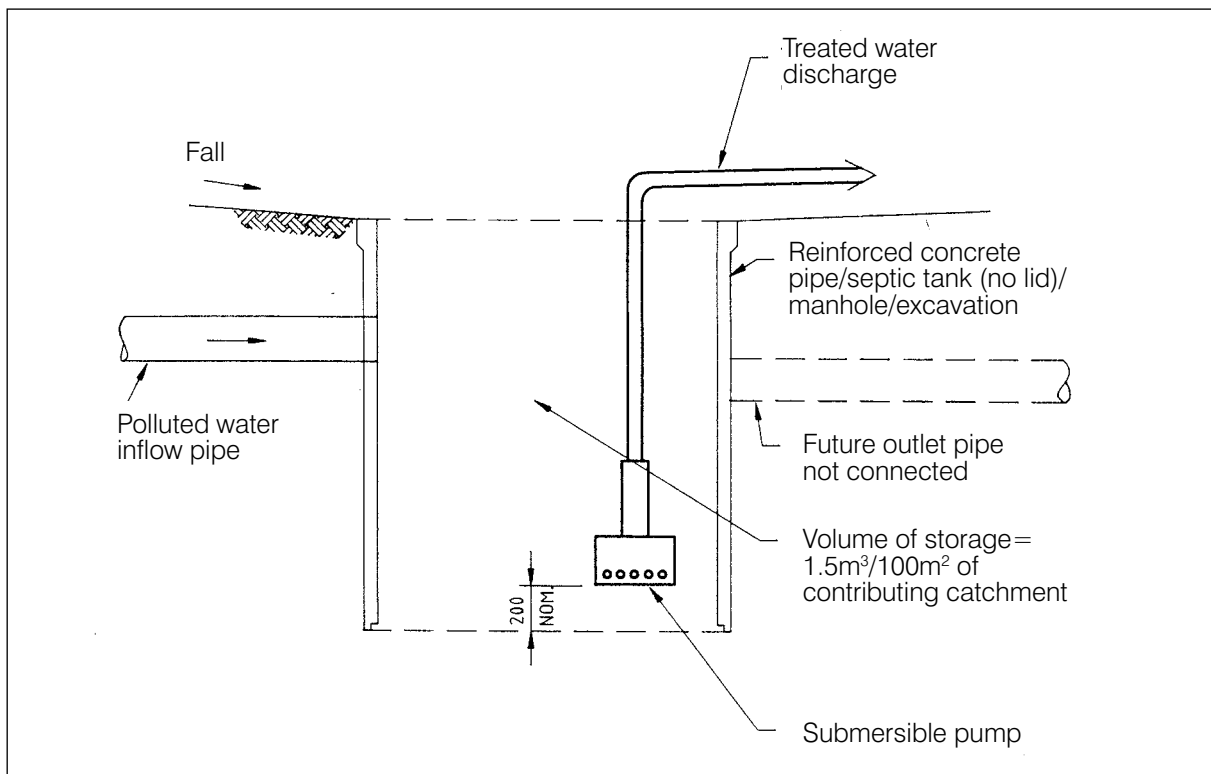
**Figure 9: Sediment Pit**

Discharge from the pit is permissible when the water pH is 6.5-8.5 and is clarified to at or below 60mg/L (50 NTU) for urban areas and for other areas on the advice of the EPA. Gypsum dosing rate should be applied at about 30 kilograms per 100 cubic metre of stored water. In some instances higher rates may apply, typically less than 50 mg/Litre. If dosing with alum, ensure it is done in accordance with the Blue Book.

Ensure the submersible pump is suspended from the base of the pit to ensure sediment/sludge is not collected during discharge.

Manage water so dosing and discharge can be achieved in a timely manner before the next rain event. Water should be discharged when it is above 20% of the pit's full capacity. Records must be kept of all measurements prior to, during and after discharge. See Schedule 11.3.

#### 4.9 Sediment Traps for Channelled Run-Off

A sediment trap is a temporary sediment control device to intercept and retain sediment from channelled sediment laden run-off.

##### Conditions Where Practice Applies

A sediment trap is usually installed in either a floodway, at a storm drain inlet, or other points of discharge from a disturbed area.

##### Cleanout

Sediment shall be removed and the trap restored to the original dimensions when the sediment has accumulated to 1/2 of the design depth of the trap.

## Outlet

The outlet shall be designed, constructed and maintained in such a manner that under operating conditions sediment does not leave the trap and that erosion does not occur.

Sediment traps may outlet onto stabilised (preferably undisturbed) ground. If there is no area available, it is permissible to discharge to the stormwater system when the water pH is 6.5-8.5 and is clarified to at or below 60mg/L (50 NTU) for urban areas and for other areas on the advice of the EPA. Gypsum dosing rate should be applied at about 30 kilograms per 100 cubic metre of stored water. In some instances higher rates may apply, typically less than 50 mg/Litre. If dosing with alum, ensure it is done in accordance with the Blue Book.

## Drainage Area for Various Types of Sediment Traps

The drainage area for sediment traps shall be in accordance with the specific type of sediment trap used, as per the following criteria:

<i>Type</i>	<i>Max Catchment Ha</i>
Rip-Rap Outlet Sediment Trap	5
Grass Outlet Sediment Trap	2
Rock Bund/Gabion	1
Geotextile Sediment Trap	0.5
Straw Bale Check Dam	0.5

## Design Criteria

**Rip-Rap Outlet Sediment Trap** consists of a trap formed by an excavation and embankment. The outlet for this trap shall be through a partially excavated channel lined with stone rip-rap. This outlet channel shall discharge into a stable watercourse or onto a stabilised area. Rip-rap outlet sediment traps may be used for drainage areas of up to a maximum of 5 Ha.

Riprap outlet sediment trap dimensions are provided in the following table:

<i>Drainage Area Ha</i>	<i>Depth of Channel (metres)</i>	<i>Length of Weir (metres)</i>
0.5	0.5	1.5
1.0	0.5	1.5
1.5	0.5	3.0
2.0	0.5	3.5
2.5	0.6	3.5
3.0	0.6	3.75
3.5	0.6	4.0
4.0	0.6	4.0
4.5	0.6	4.0
5.0	0.6	5.0

**Grass Outlet Sediment Trap** consists of a trap formed by excavating the earth to create a holding area. The trap has a discharge point over natural existing grass. Grass outlet sediment traps shall be limited to a 2 Ha maximum drainage area. Required storage shall be 50 cubic metres per Ha of drainage.

**Rock Bund/Gabion** (Figure 10) consists of a trap formed by rock, 50mm aggregate or equivalent wrapped in geotextile fabric, wire mesh or equivalent.

**Figure 10: Rock Bund/Gabion**

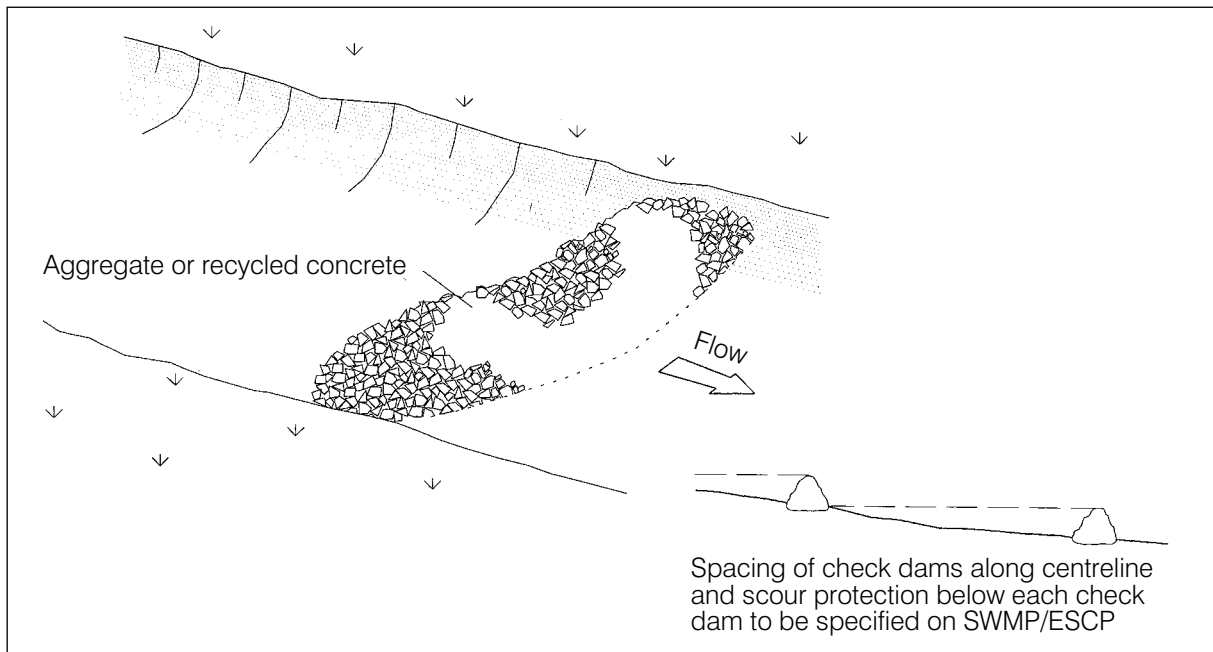
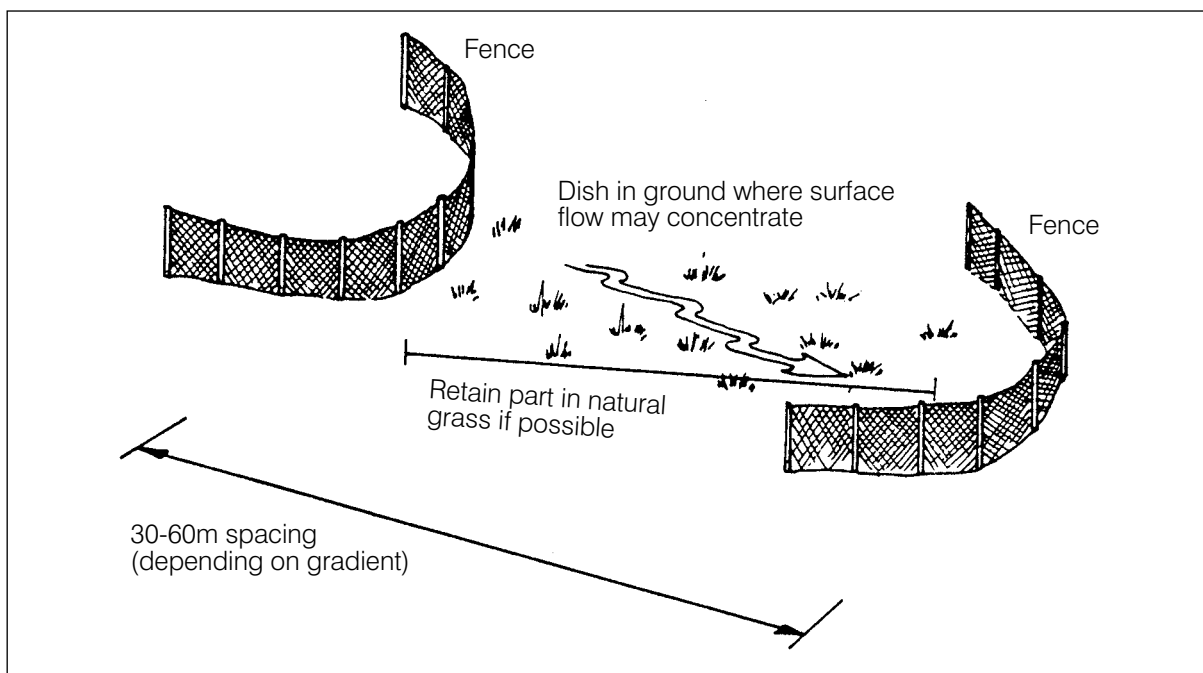

Illustration reproduced courtesy of Landcom

**Geotextile Sediment Trap** (Figure 11) consists of a sediment control barrier used on minor drainage lines with more critical strength requirements. They are spaced at 30–60m intervals down the drainage line. Contributing drainage area should be limited to 0.5 Ha between successive lines and/or one sediment control barrier/0.5 Ha of total catchment.

**Figure 11: Geotextile Sediment Trap**

**Straw bale check dams** (Figure 12 and 13) may be utilised upstream of other controls as a complementary measure or on minor drainage lines of less than 0.5 Ha and located at specified intervals to minimise erosion. Straw bales must be maintained and replaced regularly. If measures are required for longer periods then the bales should be wrapped in biddum.

Straw bale installation:

- Dig a trench 100 mm deep to stop water running under the straw bale. The trench should be as wide as the straw bale and as long as needed along the contour lines of the block.
- Put the bales lengthways along the trench. Use straw to fill any gaps between bales. Bind bales along the side rather than top and bottom as they will hold together better when wet.
- Fix the bales in place using two 1.2 m star pickets at each end of each bale. Angle one stake towards the previously laid bale before driving it 600 mm into the ground. Put the other stake in vertically.
- Backfill and compact the trench to ground level on the downslope side of the straw bales. On the upslope side, build up the soil to 100 mm. This will slow down the speed of the water flows and trap coarse sediments.
- Straw bales must be maintained and replaced regularly.

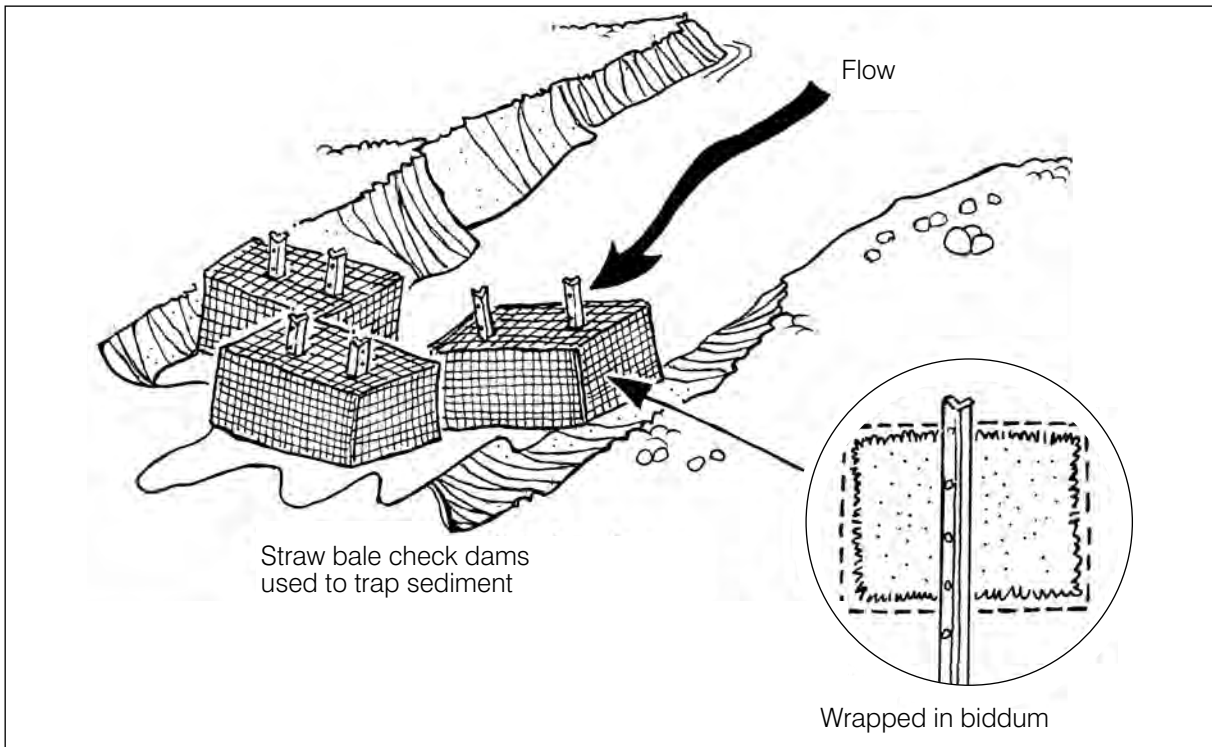
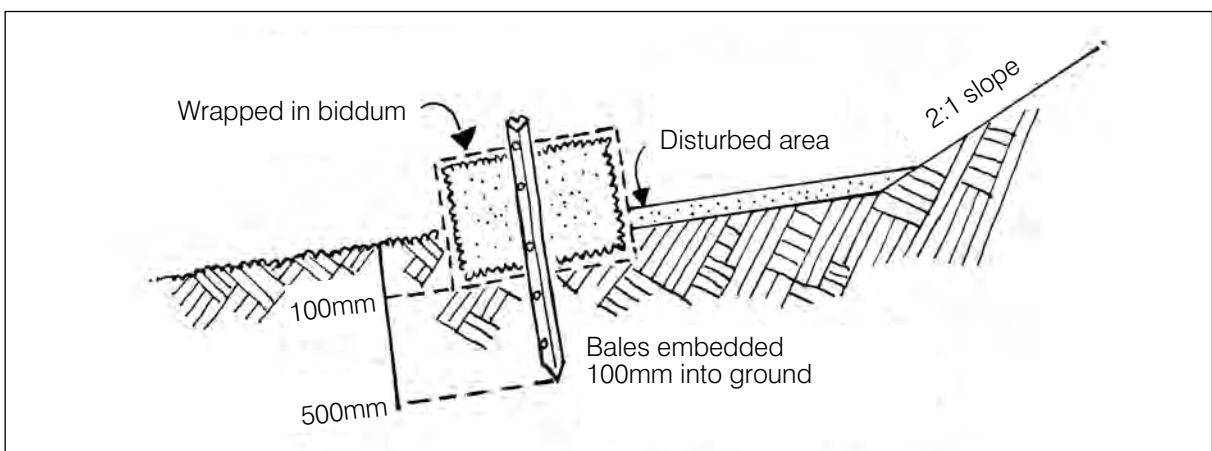
**Figure 12: Straw Bale Check Dam****Figure 13: Straw Bale Check Dam Detail**

#### 4.10 Sediment Control Barrier

A temporary barrier of geotextile fabric can be used to intercept sediment laden run-off from small drainage areas of disturbed soil (Figure 14 and 15).

##### Construction Notes

The sediment control barrier should be in place prior to commencement of building works; should be retained until revegetation is fully established after building has been completed; and should be checked daily.

Geotextile fabric installation:

- Identify low point of site
- Construct a sediment control barrier parallel to contours of site or as close as possible

- Put 1.5 m star pickets no more than 2.5-3 m apart and 600 mm deep.
- Put a star picket 1.5 m upslope of the others every 20 m (if the fence is longer than 20 m). This spreads the volume of water that flows through each section of fence.
- Dig a trench and bury the base of the sediment control fabric. The trench should be 150 mm deep. Alternatively, use backfill or aggregate to make sure the fabric is tight on the ground.
- Use wire ties to attach the fabric to the upslope side of the fence posts.
- If you need to join two pieces of fabric, ensure the fabric overlaps at least 150 mm and is supported by a star picket.

**Figure 14: Geotextile Fabric Sediment Control Barrier**

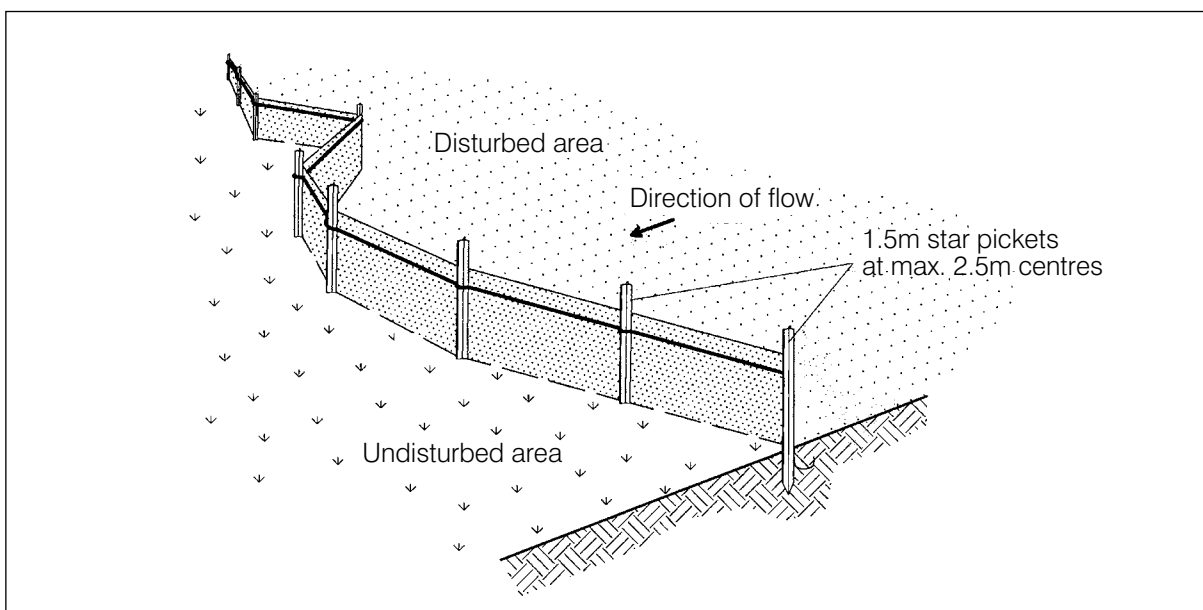
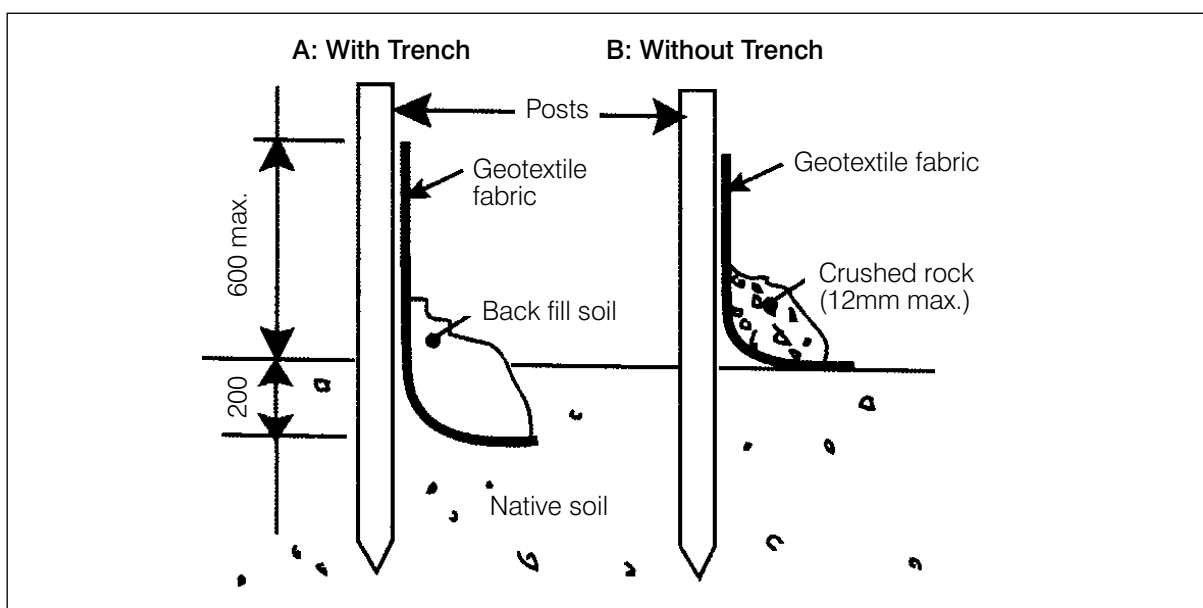

Illustration reproduced courtesy of Landcom

**Figure 15: Geotextile Fabric Sediment Control Barrier**



## 4.11 Stockpile Management

Loss of material through incorrect storage of stockpile and building materials can be a major source of pollution and increase costs for the builder.

- Place stockpiles near the stabilised access point to reduce damage to the site.
- When ordering materials, give clear instructions on where they should be placed on site.
- Clearly mark stockpile area.
- Limit the amount of material stockpiled onsite if possible.

To protect stockpiles and building materials from entering the stormwater system:

- store them behind sediment control barriers;
- cover them where necessary;
- locate them away from high water flow areas; and
- keep topsoil stockpile height below 2 m.

### Maintenance of Stockpiles

Ensure controls are checked daily and repairs undertaken immediately. Ensure controls are put back in place if they are moved for any reason.

**Figure 16: Stockpile Management**

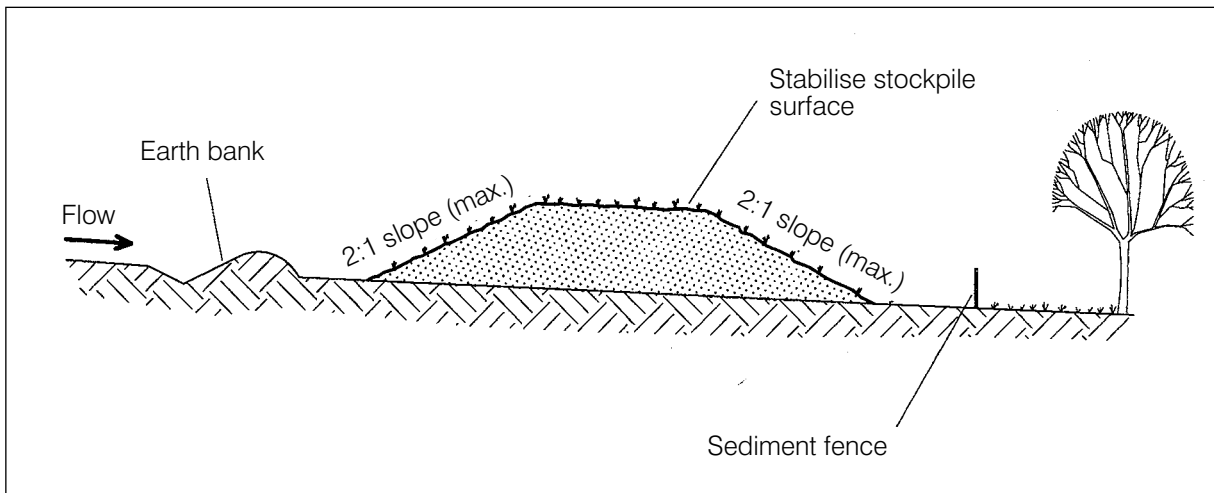

Illustration reproduced courtesy of Landcom

## 4.12 Stormwater Inlet Protection

The purpose of an inlet protection device is to prevent sediment laden water from entering a stormwater drainage system (Figures 17 and 18).

### Conditions Where Practice Applies

This practice shall be used where the drainage area to an inlet is disturbed and it is not possible to temporarily divert the stormwater drain outfall into a sediment trapping device and watertight blocking of inlets is not advisable. It is not to be used in place of sediment trapping devices. Stormwater inlets

must be maintained and checked regularly and road should be cleaned at the end of every day and particularly before and after rain events.

**Figure 17: Kerb Inlet Control**

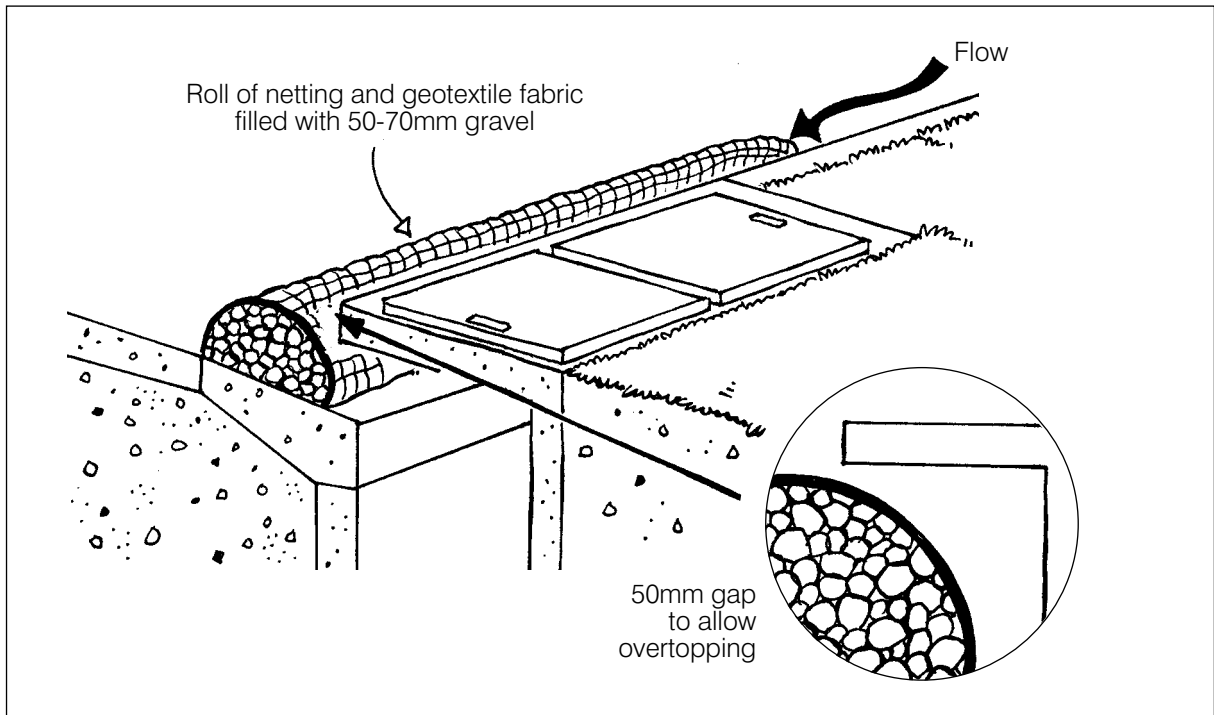

**Figure 18: Stormwater Inlet Sediment Control**

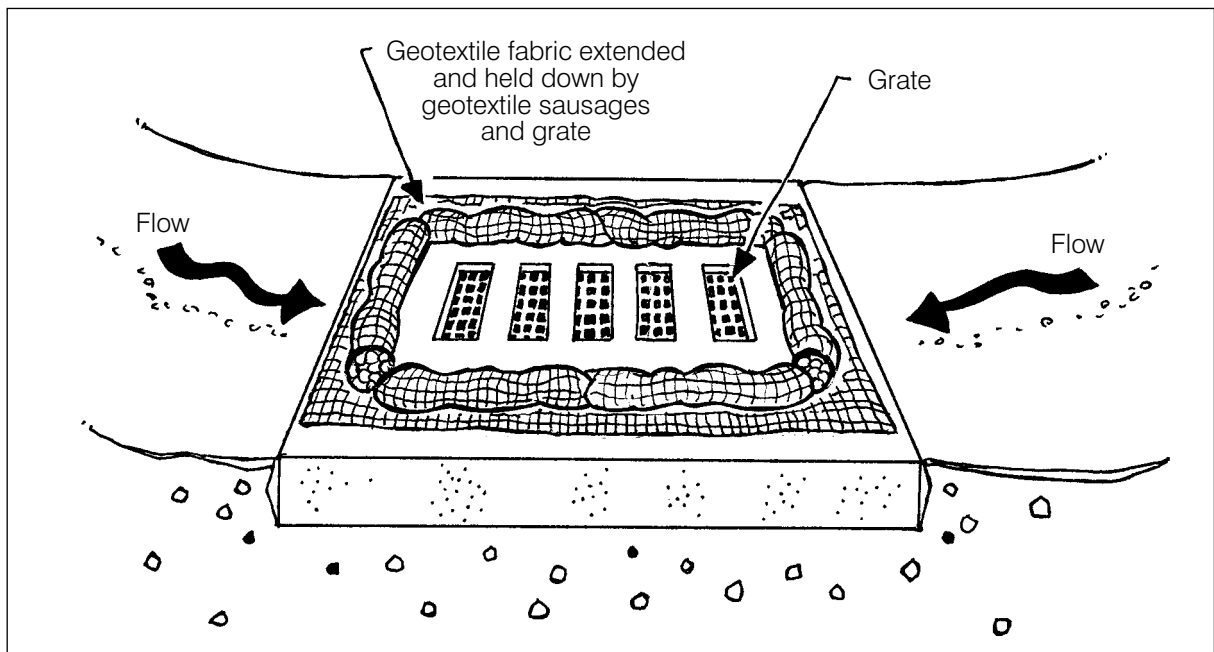

## 5 SPECIALISED EROSION AND SEDIMENT CONTROLS

### 5.1 Works Within A Waterway

Procedures designed for installing a pipe or line across a stream while protecting the waterway from erosion and sediment damage are outlined in Figure 19. Stream diversion may be in the stream bed, via a piped culvert or via an excavated channel which is stabilised with lining or similar. You may require a permit under Section 44 of the *Water Resources Act 2007* to undertake work in a waterway. Contact the EPA for more information.

**Figure 19: Stream Diversion**

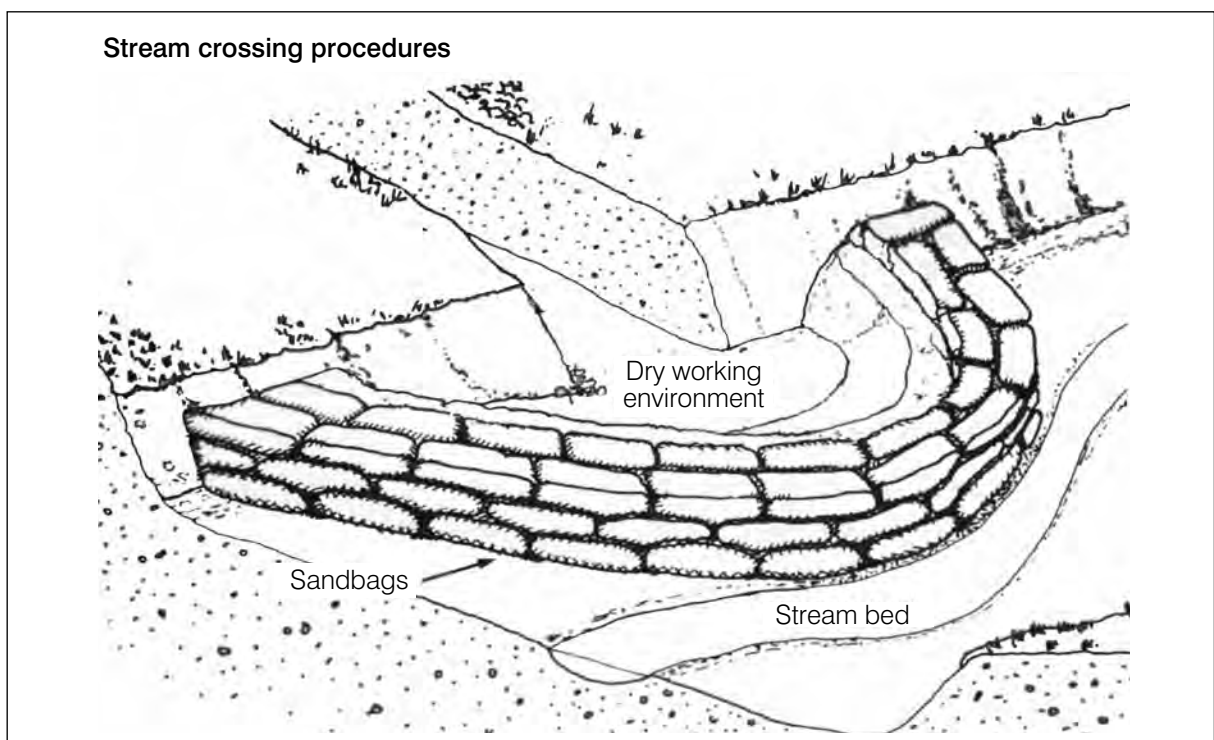

### 5.2 Temporary Waterway Crossing

A temporary waterway crossing is a temporary structure placed across a waterway to provide access for construction purposes. Temporary access crossings shall not be utilised to maintain traffic for the general public. You may require a permit under Section 44 of the *Water Resources Act 2007* to undertake work in a waterway. Contact the EPA for more information.

The three types of standard temporary waterway crossings are bridges, culverts, and fords. A culvert is normally preferred over a ford type of crossing, since disturbance to the waterway is only during construction and removal of the culvert. Temporary fords may be used where the stream banks are less than 2m above the invert of the stream, and the streambed is armoured with naturally occurring bedrock, or can be protected with an aggregate layer in conformance with this specification.

**Figure 20: Temporary Waterway Crossing**

Illustration reproduced courtesy of Landcom

### Design Criteria

- In-stream excavation shall be limited to only that necessary to allow installation of the standard methods for temporary waterway crossing as presented in the Blue Book.
- All fill materials associated with the roadway approach shall be limited to a maximum height of 600mm above the existing floodplain elevation.
- A water diverting structure such as a swale shall be constructed (across the roadway on both roadway approaches) 15m (maximum) on either side of the waterway crossing.
- All crossings shall have one traffic lane. The minimum width shall be 4m with a maximum width of 6m.
- All crossings shall be designed and checked so as not to cause upstream flooding of any works or facilities.
- There shall be no earth or soil used for construction within the waterway channel. Coarse aggregate (of 100mm to 150mm size) shall be the minimum acceptable aggregate size for temporary crossings. Larger aggregates will be allowed.
- All temporary crossings shall be removed within 1 month after the structure is no longer needed.
- Clean up shall be accomplished without construction equipment working in the stream channel. All areas shall be stabilised within 21 calendar days of the disturbance.

### 5.3 Portable Sediment Tank

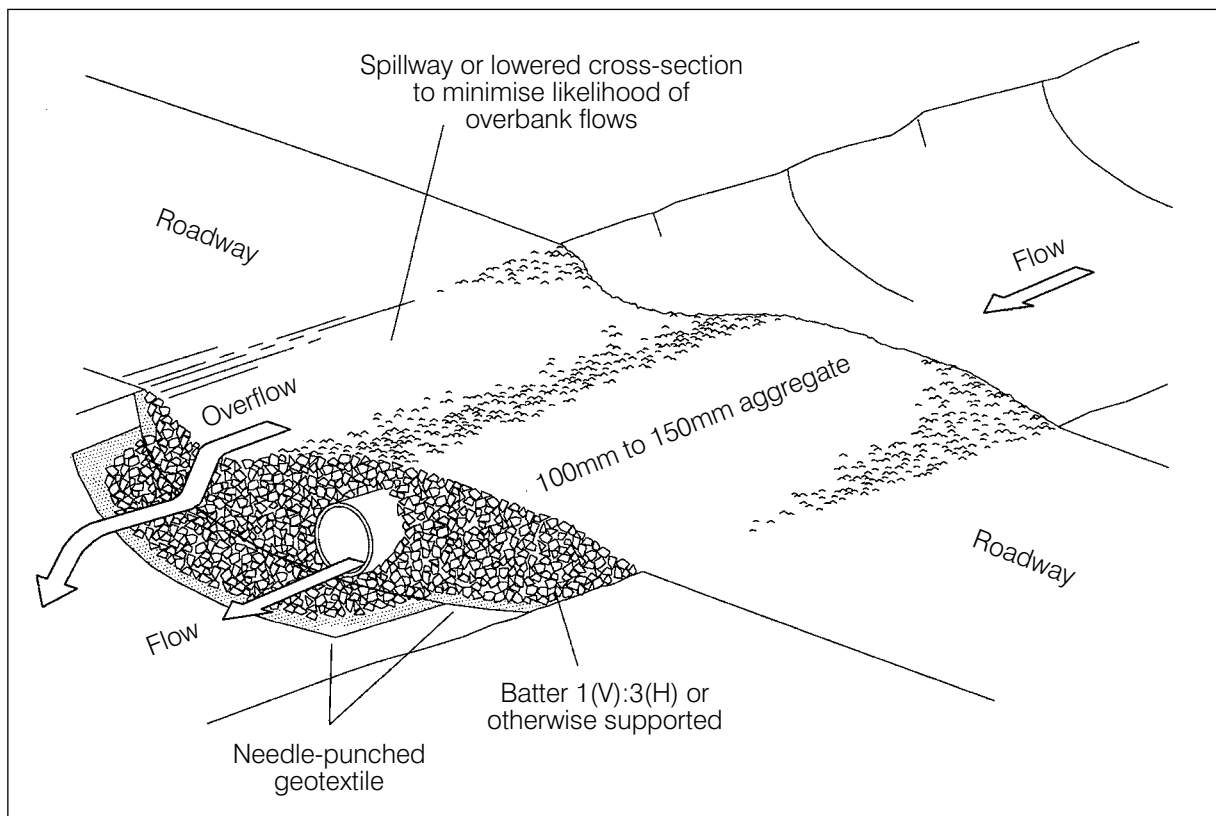
The purpose of a portable sediment tank is to trap and retain sediment and treat turbid water prior to pumping the water to the stormwater system.

**Figure 21: Portable Sediment Tank**

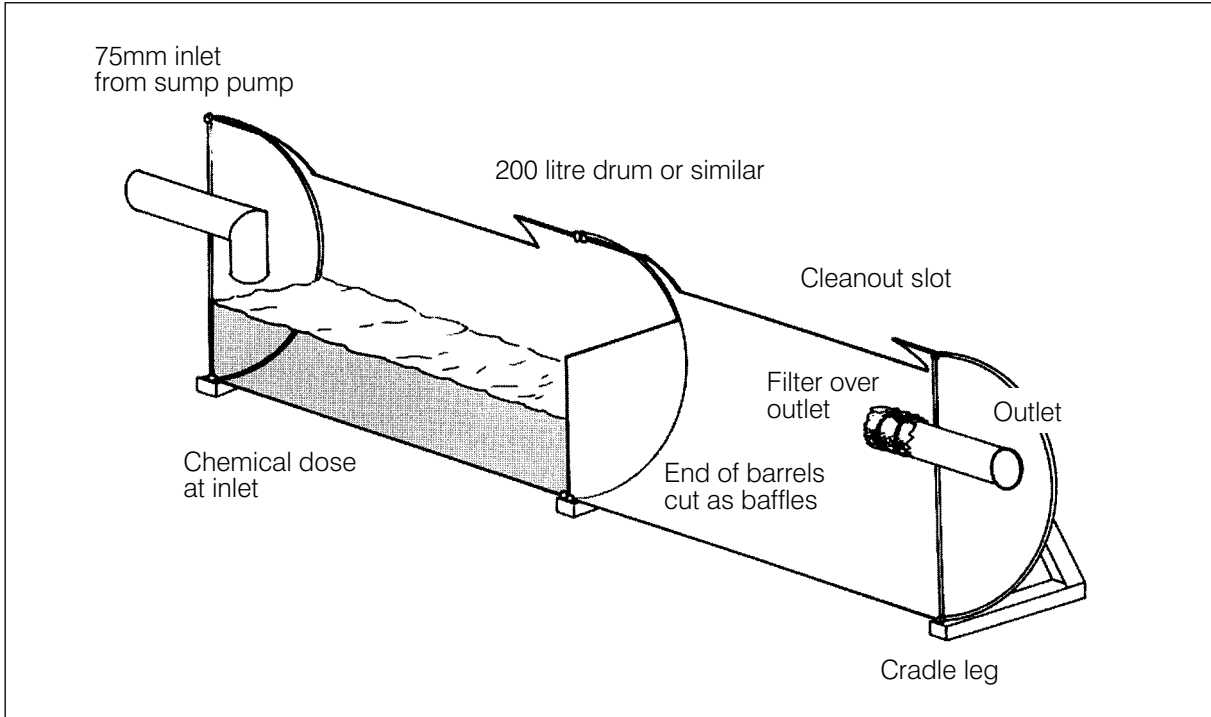

#### Conditions Where Practice Applies

A sediment tank can be used on sites where excavations are deep, and space is limited, such as urban building sites.

#### Discharge

Discharge from the tank is permissible when the water pH is 6.5-8.5 and is clarified to at or below 60mg/L (50 NTU) for urban areas and for other areas on the advice of the EPA. Gypsum dosing rate should be applied at about 30 kilograms per 100 cubic metre of stored water. In some instances higher rates may apply, typically less than 50 mg/Litre. If dosing with alum, ensure it is done in accordance with the Blue Book.

Manage water so dosing and discharge can be achieved in a timely manner before the next rain event. Water should be discharged when it is above 20% of the tank's full capacity. Records must be kept of all measurements prior to, during and after discharge. See Schedule 11.3.

### 5.4 Downdrain Structure (Slope Protection Structure)

A downdrain structure is a pipe or chute structure installed down steep slopes for the conveyance of runoff. Maximum drainage area shall be 10 Ha without special design and adequate spillway provision (Figure 22).

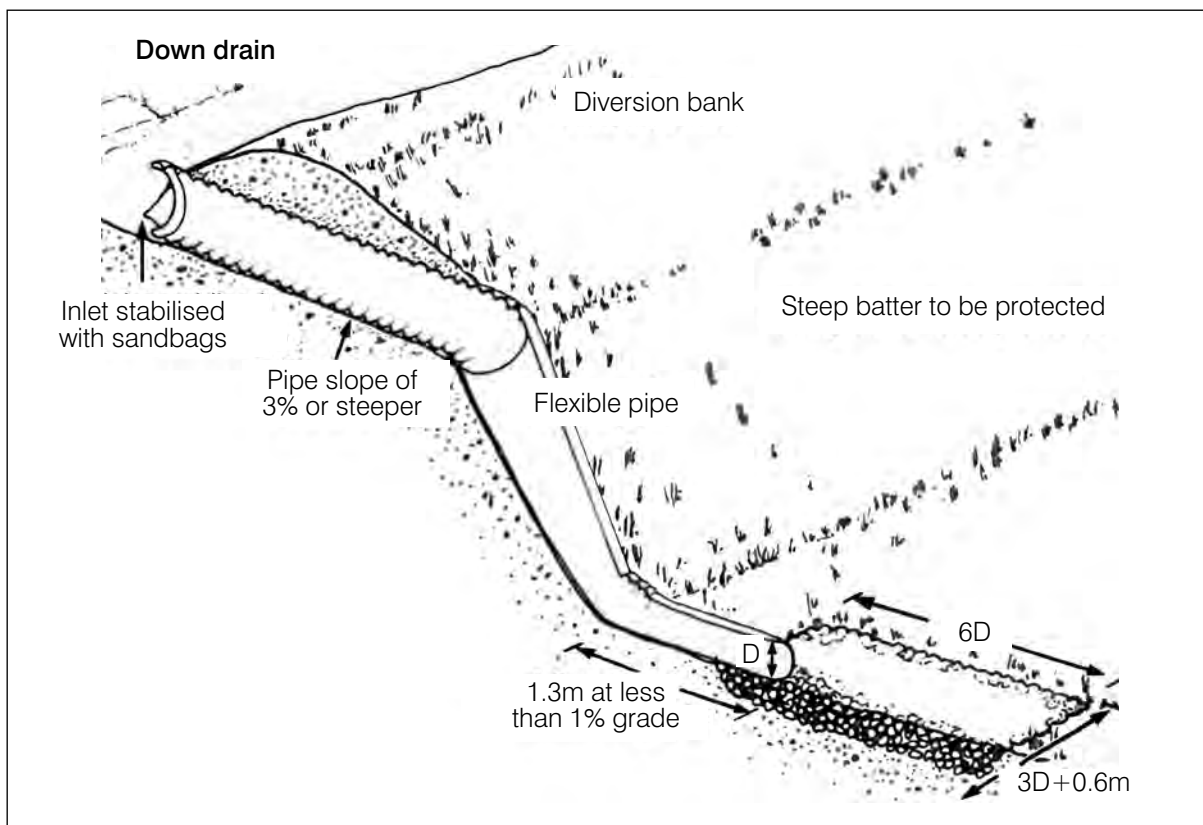
**Figure 22: Down Drain**

### Design Criteria for Downdrains

Downdrains consist of:

- Pipes of concrete, corrugated steel, cast iron.
- Flexible conduits of heavy duty fabric, or other material (usually a temporary installation).
- Chutes of half round pipes of concrete, corrugated steel, (permanently staked), U sections of concrete nestled together, grouted rock or spraycrete.

The downdrain shall outlet into a sediment trapping device when the drainage area is disturbed. A riprap apron shall be installed below the pipe outlet where clean water is being discharged into a stabilised area.

## 5.5 Trenches

Where possible, open only the amount of trench that can be filled in one day or before a storm event. If this cannot be done, ensure sediment control measures are in place.

Spoil heaps should be placed on the uphill side of the trench. If one end of the trench is down slope from the other, a sediment control barrier should be erected at the low end of the trench to filter sediment and assist to slow water flow.

If the trench needs to be pumped dry, the water should be discharged according to Section 4.7 Sediment Trench.

Trenches should be backfilled, capped and compacted as required by the Standard Specifications for Urban Infrastructures Works (Department of Urban Services). A sediment control barrier should be erected downstream to capture sediment in the runoff and should be regularly maintained.

Unless sealing (e.g. paving, bitumen, etc) the area will occur within 30 days, the disturbed area should be turfed or sown with an appropriate seed and fertiliser mix (see Section 4.1 Vegetative Cover).

## 6 NOISE

Ensure all building work that generates noise is conducted within the time periods detailed in Schedule 2 of the Environment Protection Regulation 2005.

<i>Building Work Details</i>	<i>Monday to Saturday</i>	<i>Sunday and public holidays</i>
Industrial, city and town centre areas	6am to 8pm	6am to 8pm
Any other area when work completed within 2 weeks	7am to 8pm	8am to 8pm
Any other area when work not completed within 2 weeks	7am to 6pm	Building work must not exceed Noise Standard

In addition:

- schedule noisy activities for the least sensitive times of the day such as mid-morning and mid-afternoon;
- select machinery that produce less noise; and
- ensure machinery is well maintained.

---

## 7 AIR QUALITY

---

### 7.1 Dust

Where building work generates dust, all reasonable and practicable measures should be taken to minimise that dust.

This can often be achieved by:

- retaining existing vegetation where possible;
- stripping areas progressively and only where it is necessary for works to occur;
- employing stabilisation methods such as matting, grassing or mulch;
- dampening the ground with a light water spray (contact the EPA for requirements during extreme drought conditions);
- roughening surface of exposed soil;
- covering stockpiles and locating them where they are protected from the wind;
- restricting vehicle movements;
- covering the load when transporting material; and
- constructing wind breaks such as wind fences in accordance with the Blue Book.

When an area of works is completed, the area should be revegetated immediately to inhibit the generation of dust.

### 7.2 Fire

Burning of waste materials on the site, such as plastics, chemicals or wood that is painted, chemically treated or contaminated with chemicals is illegal. A fire may be permitted for heating purposes provided it is in a brazier or constructed fireplace. Only seasoned, untreated timber can be burnt for heating purposes.

## 8 SPOIL MANAGEMENT

---

The developer/builder must be aware of the following information before disposing spoil off site or accepting soil on site.

### 8.1 Disposal of Spoil

Before disposal of spoil off site, the following information must be provided to the EPA:

- where the spoil will originate from;
- who is disposing of the spoil;
- where the spoil will be taken;
- the amount of spoil to be taken away;
- description of the type of spoil taken away;
- details of how records will be kept; and
- timeframe to complete works to the satisfaction of the EPA.

Spoil may be taken to an approved landfill sight without approval. However, if the spoil is taken to an area other than an approved landfill site, ensure the acceptor of the spoil is aware of the requirements in Section 8.2.

No material from a potentially contaminated site is to be removed off-site for re-use or disposal without EPA approval. For more information in relation to contaminated soil, refer to 'Contaminated Sites Information Sheet 4, Requirements for the Re-use and Disposal of Contaminated Soil'.

### 8.2 Acceptance of Soil

Under the Act, the acceptance of more than 100m<sup>3</sup> of soil by the lessee or occupier of the land in most areas of the ACT requires an Environmental Authorisation. This includes land that is in an area identified in:

- the Territory Plan as Broadacre; Rural; Hills, Ridges and Buffer Areas; River Corridors; Mountains and Bushlands; Plantation Forestry; or
- the National Capital Plan as Broadacre Areas; Rural Areas; Hills, Ridges and Buffer Spaces; River Corridors; Mountains and Bushland.

If the soil is to be accepted at a site other than those listed above, an authorisation is not required, however, the EPA must be notified. (Notification is not required if taken to an approved landfill site).

Before accepting soil on site, ensure the following points are followed to reduce the risk of receiving contaminated material:

- ensure that all fill used is virgin excavated material (e.g. clay, gravel, sand, soil or rock) that is not mixed with any other waste;
- request the supplier provide formal certification that fill is clean;

- 
- request the supplier provide information on what activities previously occurred on site;
  - check for signs of contamination, such as odours (chemical/petrol), staining from chemicals, and rubbish such as bricks, timber, masonite, etc;
  - supervise the delivery of the material to ensure you receive only what you have ordered; and
  - maintain all documents and records.

No material is to be placed in a waterway without prior approval from the EPA.

Material from a known or potentially contaminated site must not be accepted without EPA approval.

Illegal acceptance of more than 100m<sup>3</sup> of soil may attract penalties of up to \$100,000.

## 9 REFERENCES

---

Includes, but is not limited to:

- *Environment Protection Act 1997*
- Environment Protection Regulation 2005
- *Water Resources Act 2007*
- Magistrates Court (Environment Protection Infringement Notices) Regulation 2005
- Guidelines for Preparation of an Environment Management Plan, ACT EPA
- General Environment Protection Policy, ACT EPA
- Water Quality Environment Protection Policy, ACT EPA
- Air Environment Protection Policy, ACT EPA
- Contaminated Sites Environment Protection Policy, ACT EPA
- Hazardous Materials Environment Protection Policy, ACT EPA
- Noise Environment Protection Policy, ACT EPA
- ACT EPA Information Sheets
- Volume 1 of Managing Urban Stormwater: Soils and Construction (Landcom, 2004), the “Blue Book”
- Standards Specification for Urban Infrastructure Works, Department of Urban Services

---

## 10 GLOSSARY OF TERMS

---

**Acceptable Standard for Discharge (urban areas)**

Discharge is allowed when the water is clarified to below 60 mg/L (suspended solids). Based on most soil types in the ACT area, a measurement of 50 NTU is comparable to 60 mg/L.

**Annual Exceedance Probability (AEP)**

The probability that a given rainfall total accumulated over a given duration will be exceeded in any one year.

**Batter**

The sideslope of an embankment or cutting.

**Blue Book**

Volume 1 of Managing Urban Stormwater: Soils and Construction, Landcom, 2004.

**Chemically Dosed Water**

Water which has been treated with gypsum or alum or similar to reduce turbidity.

**Clean Water**

Water which runs across land which is undisturbed by building/construction works.

**Cofferdam**

A temporary enclosure formed to exclude water from an area in which construction is to take place. Cofferdams can take a variety of forms and are constructed from materials such as driven sheet piling, rock, earth or concrete.

**Cumec**

A measurement of flow rate. One cumec is one cubic metre per second.

**Diversion Drain**

An earth bank constructed across a slope for intercepting and diverting water. Typically constructed at the upper edges of cut slopes to collect water from nearby properties and divert it around the cut.

**Downdrain Structure**

A pipe or chute structure installed down steep slopes for the conveyance of runoff.

**Earth Bank**

A berm or ridge of compacted earth located in such a manner as to channel water to a desired location.

**Environment Protection Authority (EPA)**

The statutory decision maker for environmental regulation and policy in the ACT. The EPA administers legislation covering air and water quality, waste, contaminated land, noise control, pesticides and hazardous chemicals.

**Environment Protection Order (EPO)**

Instruments issued by the EPA under section 125 of the Act where the EPA is satisfied that there is a breach of the Act or an authorisation condition. The order requires the person to do, or not do, specified things to remedy the breach of the Act or authorisation.

**Environmental Authorisation**

A licence to conduct an activity which has a significant potential to cause environmental harm. An authorisation sets out the conditions under which the activity may be conducted.

**Environmental Protection Agreement**

A formal, non-contractual agreement between the EPA and a business. They are intended to allow businesses to manage their environmental performance in partnership with the EPA.

**Erosion and Sediment Control Measures**

Includes the protection of soil from dislocation by water, wind or other agents. Also includes all measures used to slow down loss of sediment from construction activities.

**Geotextile Fabric**

A synthetic fabric, woven or non woven, used for various purposes including:

- embankment reinforcing and stabilization (including channels)
- seepage control
- pollution containment
- providing a filter layer between dissimilar materials
- as a strain alleviating membrane.

**Grid**

A device placed on the stabilised access used to open the tread on tyres and vibrate mud and dirt off the vehicle.

**Level Spreader**

A device to convert channel or pipe flow to sheet flow to prevent concentrated, erosive flows from occurring and to enhance filtration.

**Nephelometric Turbidity Units (NTU)**

A measurement of water turbidity.

**Pollution Control Plans**

A plan which addresses the management of environmental impacts of activities in a given project during construction and land development. It identifies risks to the environment for the project and the environmental requirements contained within the contract documentation and outlines key strategies for managing these risks and minimising undesirable environmental impacts.

**Portable Sediment Tank**

A portable tank used to trap and retain sediment and treat turbid water prior to pumping the water to the stormwater system.

**Riprap Apron**

Riprap aprons are flat beds of crushed rock over geotextile fabric installed at storm drain outlets. Riprap aprons are energy dissipation measures that decrease flow velocity to a non-erosive level prior to entering an earthen channel.

**Road Table Drain**

The side drain of a road next to the shoulders, having its invert lower than the subgrade level and being part of the formation.

**Rock Bund/Gabion**

A rectangular wire mesh or geotextile fabric cage filled with rock, recycled concrete, aggregate or similar hard material.

**Sediment Control Barrier**

A barrier typically consisting of permeable material stretched between and attached to supporting posts and entrenched in the earth.

**Sediment Control Pond**

A temporary or permanent storm capture device consisting of a barrier or dam or an in-ground basin constructed across the drainage outlet to intercept sediment-laden run-off and to trap and retain sediment.

**Sediment Pit**

A pit that contains polluted run-off for treatment prior to discharge which is applicable to small sites (<0.5Ha) with limited open space.

**Sediment Trap**

A temporary sediment control device to intercept and retain sediment from channeled sediment laden run-off. Can be constructed with geotextile fabric, straw bales, rock, etc.

**Sediment Trench**

A temporary structure to contain polluted run-off for treatment prior to discharge. Applicable to smaller sites particularly where the surface is relatively flat.

**Sedimentation Tank**

A tank which traps and retains turbid water for treatment prior to discharge.

**Sill**

The lower horizontal face of an opening as in a level spreader.

**Soil**

Virgin excavated natural material (e.g. clay, gravel, sand, soil and rock) that is not mixed with any other waste and that:

- has been excavated from areas that are not contaminated, as a result of industrial, commercial, mining or agricultural activities, with manufactured chemicals and that does not contain sulphidic ores or soils, or
- consists of excavated natural materials that may be approved by the EPA.

**Spoil**

Excess material which can include soil and other waste.

**Stabilised Access Point**

A stabilised pad of aggregate underlain with geotextile fabric located at any point where traffic enters/leaves a construction site.

**Stockpile**

Soil, waste, building materials stored on a construction site.

**Stormwater**

Water run-off from an urban area that is normally collected by the stormwater system.

**Stormwater Inlet Protection**

A barrier used to block pollution from entering the stormwater system inlet.

**Stormwater System**

A system of pipes, gutters, drains, floodways and channels, being public works constructed to collect or transport stormwater in or through an urban area.

**Temporary Waterway Crossing**

A temporary structure placed across a waterway to provide access for construction purposes.

**Turbidity Tube**

Transparent tube used to measure turbidity of a water sample.

**VENM**

Virgin excavated natural material (e.g. clay, gravel, sand, soil and rock) that is not mixed with any other waste and that:

- has been excavated from areas that are not contaminated, as a result of industrial, commercial, mining or agricultural activities, with manufactured chemicals and that does not contain sulphidic ores or soils, or
- consists of excavated natural materials that may be approved by the EPA.

**Water Level Indicator**

A marker that is installed in a sediment control pond or similar in the initial stages of construction. It is used to identify the amount of sediment and water contained in the pond.

---

# 11 SCHEDULES

---

## Schedule 11.1 Minimum Standards for Submission of Pollution Control Plans

The following criteria should be addressed when preparing a Pollution Control Plan for the Environment Protection Authority.

### **Contact Details** (including mobile numbers)

Company undertaking the works

Site Foreman

Project Manager

### **General**

Plans must be architecturally drawn

Provide two A3 copies of the plan

Include a clear legend and orientation

Indicate Block, Section and District

Indicate the intent of the plan, i.e. Demolition, Civil Works or Construction

Indicate total site area

Illustrate clear site boundaries

Illustrate contours

Illustrate overland water flow paths and appropriate controls

Detail staging of works

Specify location of site shed/s

Provide details and location of contractor parking

### **Stabilised Access Point**

Identify stabilised entry/exit points

Describe construction specifications

**Sediment & Erosion Controls** (may include sediment fencing, filter rolls, diversion/catch drains, etc.)

Provide details using diagrams and explanatory notes

### **Sediment Control Pond** (blocks > 1 ha)

Specify location and pond size

Provide details of catchment area (including areas outside site boundary)

Provide information regarding dosing and discharge as detailed in the Guidelines

Material Stockpile and Waste Management (including concrete truck wash-down and brick cutting area)

Specify location

Detail controls

Please note that material and waste must be located on-site unless you receive

approval from Territory and Municipal Services or other land manager for temporary use of the nature strip.

**Dust Suppression**

Provide details for dust suppression (including spoil management and covering & securing loads entering & exiting the site)

Seek alternatives to water where possible (Some examples can be found in the Guidelines)

**Maintenance of Controls**

Provide details of pollution control maintenance schedule including daily/weekly inspection of stabilised access, sediment erosion controls, adjacent roads, etc. (An example can be found in Schedule 11.2)

**Spoil Management**

Indicate if it is a balanced site

If it is not a balanced site, provide details of spoil quantity, description, destination, transporter, etc. (Requirements are detailed in Section 8)

**Noise Management**

Indicate days and hours of operation (Requirements are detailed in Section 6)



## 12 NOTES

---